



Cafitesse Excellence Compact

USER MANUAL ENGLISH (US)

Cafitesse Excellence Compact

Operator Manual

Safety	2
Part overview description	4
Technical data	6
Machine start up & storage	7
Hygiene and pack handling	8
Daily operations	10
Brewing a cup of coffee / hot water / pot of coffee	10
Ingredient pack replacement	12
Filling ingredient canister	13
Filling water tank	14
Cleaning	15
User programming	27
Troubleshooting	32

Safety

Symbols that can be found in this manual

The following symbols are used throughout this manual in combination with a statement to emphasize important and critical information. Observe the statements to ensure safety and prevent injury and product damage.



Note:

Gives additional information which may be helpful during the dispenser operation.



Caution:

Alerts against unsafe practices. Observe to ensure food safety, to prevent minor personal injury, or damage to the dispenser.



Warning:

Indicates a potentially hazardous situation which, if not avoided, could result in serious injury and even death.



Danger:

INDICATES A IMMINENTLY HAZARDOUS SITUATION WHICH, IF NOT AVOIDED, WILL RESULT IN SERIOUS INJURY AND EVEN DEATH.



Operation, filling and cleaning of the dispenser must be restricted to authorized and trained persons. Take care that new staff reads the operator manual before they operate the dispenser and understand the safety and hygiene aspects. For quick reference a printed cleaning instruction label or quick reference guide is included.

You may only use the dispenser according to the instructions in this operator manual for the delivery of drinks. The manufacturer is not liable for any damage or injury resulting from improper use of the dispenser or from non-compliance with the procedures described in this operator manual.

This dispenser can be used by children aged from 8 years and above and persons with reduced physical, sensory or mental capabilities or lack of experience and knowledge if they have been given supervision or instruction concerning use of the appliance in a safe way and understand the hazards involved.

Children should be supervised to ensure they do not play with the dispenser.

Cleaning and user maintenance shall not be made by children.

Installation, relocation (fixed water version), service and programming of the dispenser is restricted to authorized service technicians. The service area is restricted to persons having knowledge and practical experience of the appliance, in particular as far as safety and hygiene are concerned.

This dispenser is not suitable for installation where a pressure washer may be used.

This dispenser must not be cleaned by a pressure washer.

The dispenser is not suitable for outdoor use.

Protect the dispenser against running water, splashes, spray or steam, heat and heavy dust.



The liquids delivered by the dispenser are hot!

Avoid scalding!

Keep hands and other body parts away from the dispenser while drinks are being dispensed and during the rinsing program.

Do not place cups, pots, or containers filled with hot liquids on top of the dispenser.

There is the risk of being scalded, in case the cups/pots/containers fall down.

Keep sufficient space around the dispenser to get away easily in case of hot liquid splashes.



Never touch the power supply or power supply plug when your hands or the power cord or plug are wet.

If the power cord of the dispenser is damaged, switch off the dispenser and contact your system supplier for replacement.

Shield the dispenser from running water, splashes, spray or steam, heat or heavy dust.

The dispenser is designed for indoor installation on a stable flat surface such as a table or a counter. Shield the dispenser from direct sunlight, frost and rain.

Make sure that there is sufficient space around the dispenser for ventilation, and front/back sides are accessible for service.

Only use water hoses and connections in compliance with EN61770.

Connect the dispenser to the drinking water line in compliance with local regulations. In case of cold drink options, test the quality of the water supply to ensure delivery of safe cold drinks according to local regulations.

If the mains cable of the dispenser is damaged, switch the dispenser off and contact your Cafitesse system supplier to have the mains cable replaced.

When connected to a wall outlet power supply, use a grounded safety plug socket in compliance with local regulations. Ensure that the electric circuit is secured by means of a fault current safety switch and that the power supply plug remains accessible after installation.

Transport and storage

Always store and transport the dispenser in the original packaging. Before storing or transporting the dispenser:

- Place the product packs in the refrigerator. Remove them from refrigerator if you plan to storage the machine.
- Clean the dispenser.
- Contact your Cafitesse system supplier so that an authorized and trained service technician can drain the water from the boiler and protect the dispenser against frost damage.



The dispenser may not be subject to frost during operation, storage or transport.

Part Overview Description

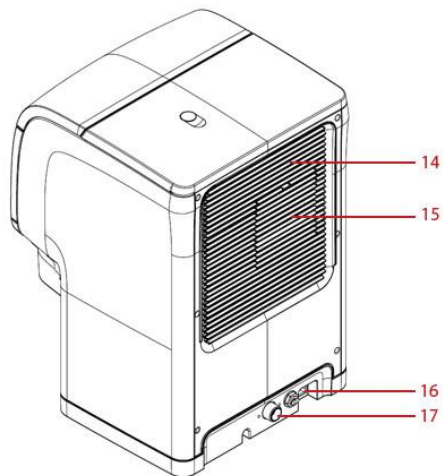
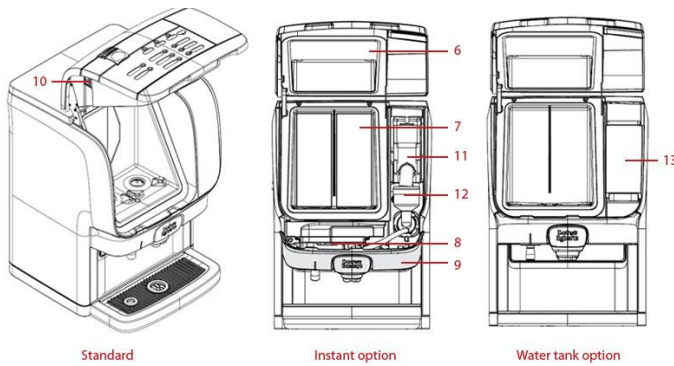

1. Drink buttons
2. Drink outlets
3. Hot water outlet
4. Cup tray
5. Drip tray
6. Dispenser door
7. Cooling compartment
8. WJM top tray
9. Fluid treatment panel
10. Stand by/lock dispenser button
11. Ingredient canister *
12. mixing bowl *
13. Internal water tank **

14. Air ventilation
15. Removable ventilation cover
16. Main socket
17. Water connection

* Only for machine with instant option.

** Only for machine with internal water tank

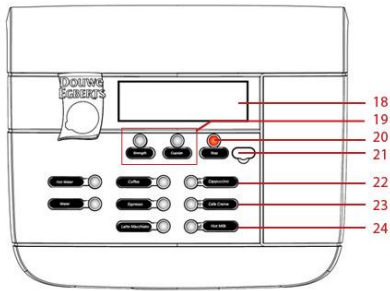

- 18. Display
- 19. Pre-selection buttons
- 20. STOP button
- 21. Port for USB key
- 22. Operator Mode: (up)
- 23. Operator Mode: (down)
- 24. Operator Mode: (enter)

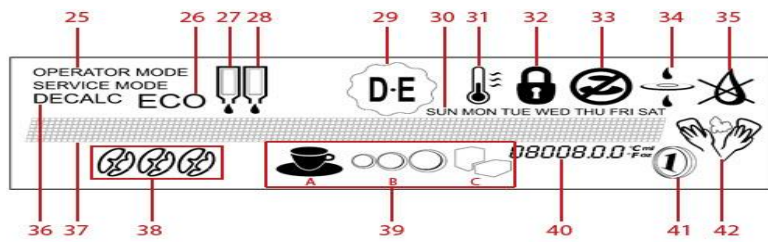

- 25. Operator/service mode
- 26. The energy saving mode is active
- 27. Product pack left is empty
- 28. Product pack right is empty
- 29. Logo
- 30. Current day
- 31. Low temperature, boiler is heating up
- 32. LOCK
the dispenser is locked and cannot dispense drinks
- 33. DELIVERY BLOCKED
the dispenser cannot deliver the selected drink
- 34. FILTER, replace water filter
- 35. The internal water tank is empty, refill the tank
- 36. Descaling of the dispenser is needed
- 37. MESSAGE-line messages are displayed to guide you through the cleaning, programming steps, or in case of errors
- 38. Strength, mild, normal or strong drinks
- 39. The pre selection buttons can be lit in different combinations and have different functions depending on machine configuration.
If A+B is lit, volume, small, normal or large drink
If B+C is lit, add extra sugar (3 steps)
If only B is lit, add extra milk (3 steps)
- 40. INFO-field display of cooling compartment temperature, time, error codes, etc.
- 41. Payment is enabled
- 42. CLEANING, the dispenser needs to be cleaned

Technical data

Dimensions		(H) 560mm x (W) 380mm x (D) 406mm
		(H) 22 inch x (W) 15 inch x (D) 16 inch
Weight empty	empty	22 kg / 48.5 lbs
	operational	24 kg / 52.9 lbs **27 kg / 59.2 lbs (with water tank option)
Cup	volume	Factory setting = 125 ml / 4.2 fl oz adjustable $\pm 10\%$
	dispensing time	10 - 20 seconds (125 ml / 4.2 fl oz)
Pot	volume	factory setting = 900 ml / 30.4 fl oz adjustable $\pm 10\%$
	dispensing time	110 seconds $\pm 10\%$
	max height	160 mm / 6.3 inch
Interval between pots		160 seconds (120 V)
Power supply		120 V 60 Hz
Power consumption		1.5 kW – 15A – 120 V
Capacity	120 V	180 cups per hour (± 22.5 liter / 25.94 gal)
Environment	temperature	1 °C – 32 °C / 34 °F – 90°F for both operation and storage
	humidity	Up to 80% RH
Cooling compartment	capacity	Capacity 2x 1.25 liter / 2x 42.2 fl oz
	temperature	2 °C – 5 °C / 35.6 °F – 41 °F
Canister capacity*	Chocolate	1.2 kg / 42.3 oz (~55 cups)
	Topping	1.1 kg / 38.8 oz (~80 cups)
	Tea	1.2 kg / 43.3 oz (~1700 cups)
	Sugar	0.8 kg / 28.2 oz (~230 cups)
	Instant coffee	0.7 kg / 24.7 oz (~350 cups)
Boiler	Volume	1.2 liter / 40.5 fl oz
	Temperature	Adjustable between 83 °C – 97 °C / 181.4 – 206.6 °F
Standard water connection		1/2" or 3/8" supply line with 3/4" BSP connecting piece, drinking water line with stop valve. **Removable cold water tank, capacity 3 liter / 101.4 fl oz
Dynamic water pressure		Min. 0.08 MPa at 10 l/min - 11 psi at 2.6 gal/min
Static water Pressure		Max. 1.0 MPa - 140 psi
Highest noise emission		< 49 dB(A)

* Only for machine fitted with instant option.

** Only for machine fitted with internal water tank option.

Dispenser start up

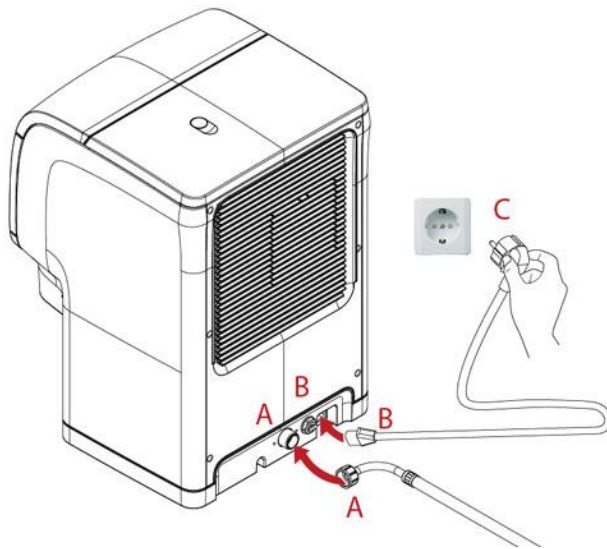

Dispenser start up

Place the machine on a flat horizontal surface that will support the weight of the machine.

Connect the water inlet hose A to A. And then open the water tap

Connect the power cord B to B, and insert the power plug C in the wall socket, the machine will start automatically and fill up and heat the boiler and cooling down the cooling compartment. Drink delivery will be blocked until the water in the boiler has reached the correct temperature.



Note:

The cooling of the product compartment can take 24 hours or more.

Dispenser storage

Please take the following preparations when the machine is not to be used for a long period, e.g. holidays:

1. Remove the product packs and check the expiry date.
2. Store the product packs in a refrigerator until you switch the dispenser back on again. When the expiry date has passed, throw the product packs away.
3. Clean and flush the dispenser.
4. Pull the power plug out of the socket.
5. Close the water tap.



Note:

If the dispenser has been shut down for longer periods, the date and time must be set so the programmed cleaning cycles and eco settings are reactivated.

Hygiene and pack handling

Always observe basic and personal hygiene.

Use only food-grade cleaning agents for the coffee dispenser. Clean the dispenser exterior parts with a clean, damp cloth.

If your coffee machine features a water tank: refresh the water inside the tank if the machine is not often used with fresh drinking water.

Ingredient pack handling <coffee pack placement>

The ingredient pack handling instructions are printed on the carton.



Observe hygiene: Wash hands before starting

Shake the pack at least 10 times and remove the plastic foil

Write date of opening and expiry date on the carton.



Pull the perforated strip from the pack



Take the dosing tube out of the carton



Slide the dosing tube over the blue ring on the carton. The red ring must cover the circle printed on the carton.



Ensure that the dosing tube is correctly placed, i.e. over the carton box



Turn the pack upside down and place inside the machine.

Daily operations

Brewing a cup of coffee / hot water / pot of coffee

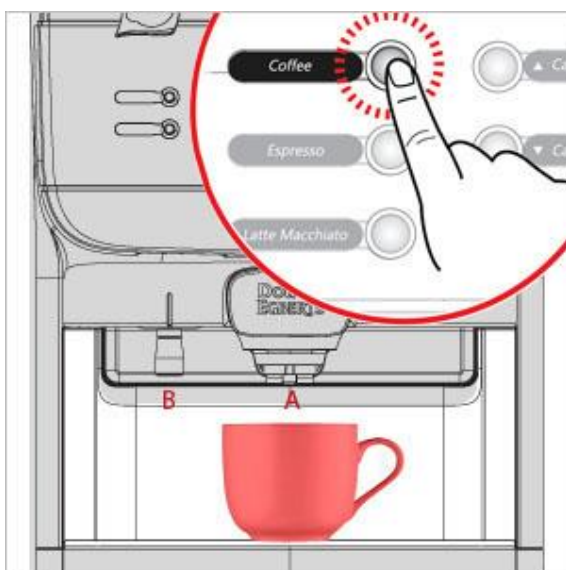

Cup of coffee or hot water

Place a cup on the drip grid under the middle outlet for coffee (A) or left outlet for hot water (B). Press a drink button



Warning:
The liquids dispensed by the dispenser are hot! Avoid scalding!
Keep hands and other body parts away from the dispenser while drinks are being delivered.
Never leave children unsupervised near the dispenser.

The machine will dispense coffee or hot water from the outlets depending on selection and stops after one cup has been delivered (portioned flow).

If the dispenser is programmed for continuous flow: Press the coffee or hot water button to start and keep the button pressed until you have obtained the desired amount of coffee or hot water.

The **STOP** button can be pressed at any moment to cancel delivery.

Pot of Coffee

Place a pot under the middle (coffee) outlet and press the pot button.



Warning:
The liquids dispensed by the dispenser are hot! Avoid scalding!
Keep hands and other body parts away from the dispenser while drinks are being delivered.
Never leave children unsupervised near the dispenser.

The machine will dispense coffee from the outlet and stop after 0,9 litre / 30.4 oz of coffee has been delivered.

The **STOP** button can be pressed at any moment to cancel delivery. You can also press the **STOP** button if you want to obtain any amount of coffee less than 0,9 litre / 30.4 oz.

Your supplier can change the standard pot volume setting on request.

Drink delivery with preselections

Your dispenser supports preselection options. The service technician may activate preselection options during installation. When the preselection button is pressed, the following pre-selections can be activated

Strength (mild, normal or strong drinks)

Volume (small, normal or large drinks)

Add extra sugar (3 steps)

Add extra milk (3 steps)



Note:

only one of volume, extra sugar and milk can be active at one time.

If you press a preselection button, but do not press the delivery button, the dispenser will return to the default state after a few seconds.

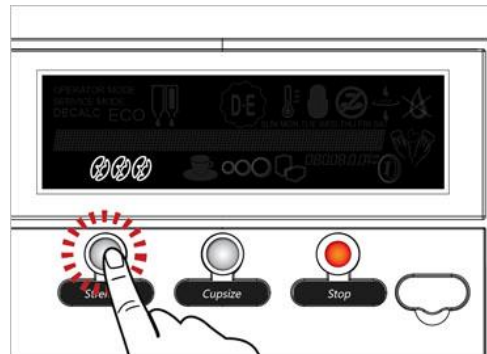

Strength preselection

1. Place your cup.
2. A bean icon (mild - normal - strong) is displayed.
3. Press a drink button. The drink will be delivered with the selected strength.

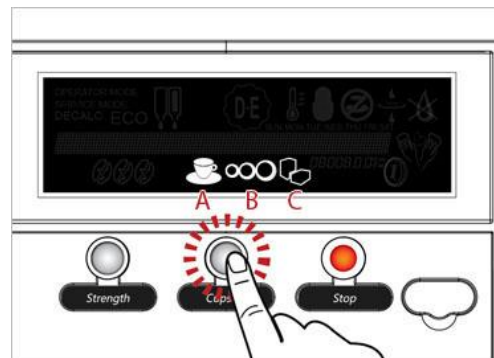

Volume preselection example

1. Place your cup.
2. Press the preselection button VOLUME to activate this preselection.
A cup icon (small - medium - large) is displayed.
3. Press the preselection button until the desired portion size is marked.
4. Press a drink button. The drink is delivered with the selected portion size.



Note:

If the icon A+B is lit the preselection button is set for "volume".

If B+C is lit the preselection button is set for "extra sugar".

If only B is lit the preselection button is set for "extra milk".

Ingredient pack replacement

The display shows an icon when a pack is empty (or almost empty) at the left / right side or at both sides (in this case the right pack is empty)
Please follow the instruction to replace a pack

[information about pack handling here](#)



Caution:

Never use a frozen or damaged product pack. Do not use a product pack if the "Best before" date has expired.



Open the machine door to access the cooling compartment and ingredient packs.

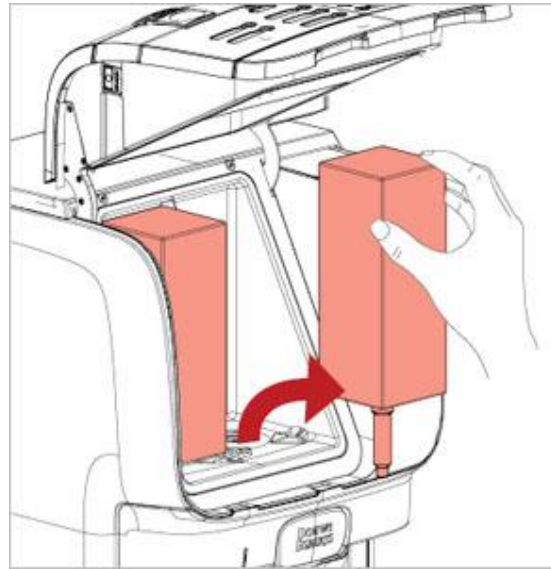

Take out the the empty ingredient pack and replace with a new one.

Filling ingredient canister



Only for machines fitted with instant option.

1. Open the door, rotate and keep the outlet of canister is upward.

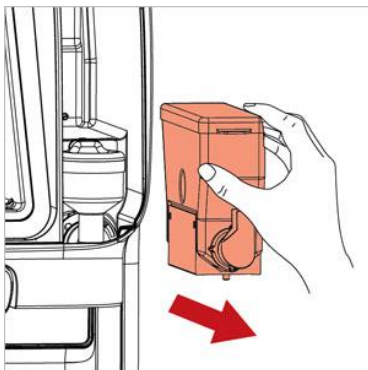

2. Take out the canister from the dispenser.

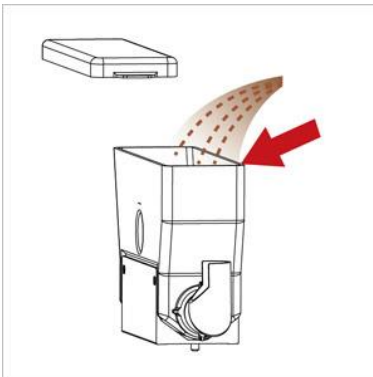

3. Fill the canister with desired ingredient.

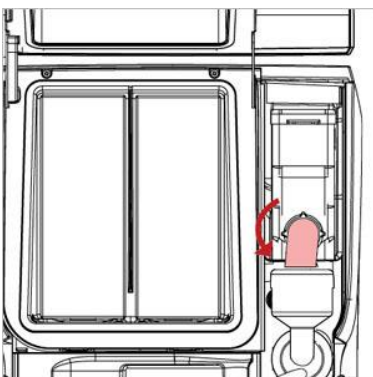

4. Put the canister back into the dispenser, rotate the canister outlet back so it points towards the mixer bowl, close the door and the machine is ready to use.

Filling water tank



Only for machines fitted with water tank option.

The display shows an icon when the internal water tank is empty (A). In this state the machine will also be blocked from dispensing drinks (B), it will be unlocked once the tank is refilled.

Please follow the instruction to refill the water tank.

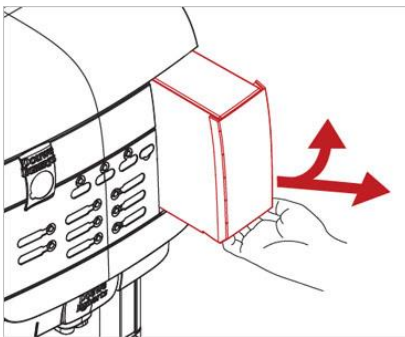

1. Grab the tank in the handle at the front. push slightly up while pulling the tank straight out.



2. Fill up the tank to the MAX indication (3L) with fresh and cold tap water.

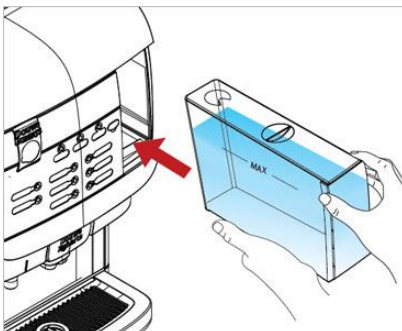

3. Put the water tank back into the dispenser. Push the tank all the way in until it hooks in place at the front.

Cleaning

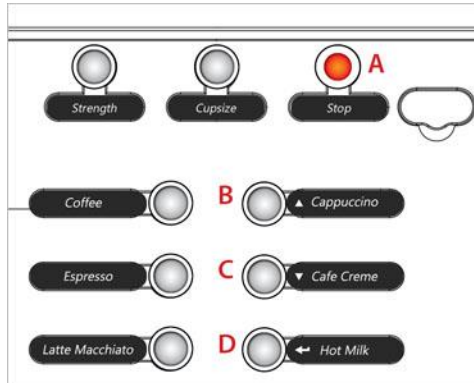

Navigation buttons

In operator and cleaning mode, 4 UI buttons are used to enter cleaning mode and navigate the menus.

A STOP = back

B Drink button top right = UP

C Drink button middle right = DOWN

D Drink button bottom right = ENTER

Cleaning procedures

There are two different cleaning programs:

- **“Flushing”** the drink outlets
- **“Cleaning”** the cooling compartment and the drink outlets.

You can select the weekdays for **“Flushing”** and **“Cleaning”** programs in the operator menu **CLEANING DAYS**.



Caution:

It is recommended to carry out the procedure **“Clean & Flush”** once a week.

When to clean the dispenser

Run the cleaning program when the cleaning icon appears in the display (See fig.1).

If the dispenser is not cleaned and/or flushed within 24 hours, the drink delivery will be blocked and the delivery blocked icon appears in the display (See fig.2).

Start and finalize the cleaning program to resume delivery.

Exterior cleaning



Note:

It is advised to clean the exterior of the dispenser daily. To prevent accidental dispensing of drinks if you wish to clean the areas around the buttons. You may lock the drink dispensing by opening the door and press the **“Standby”** button.

1. Remove the drip tray and empty it if needed, clean the drip tray with a cloth or brush under running water.

2. Clean the exterior of the dispenser with a damp, clean cloth.

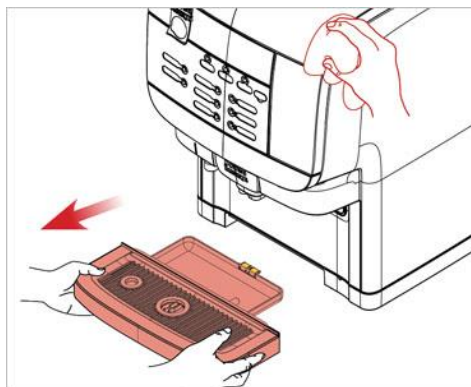
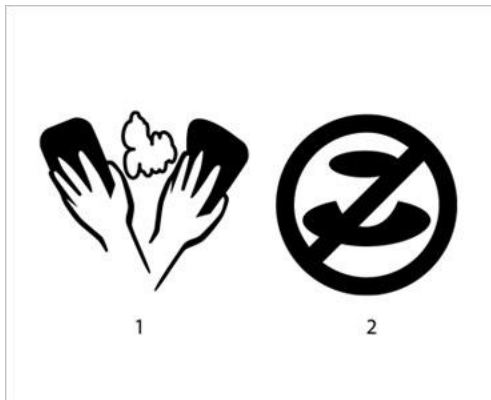

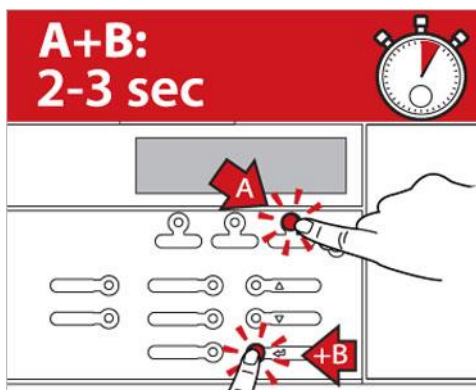

Flush



Note:

You can flush the dispenser at any time by using the procedure described below.

1. Press **STOP** and then **ENTER** button, hold them pressed simultaneously for 2-3 seconds to enter the cleaning mode.
2. The display will show **FLUSHING**, press **ENTER** button to continue.

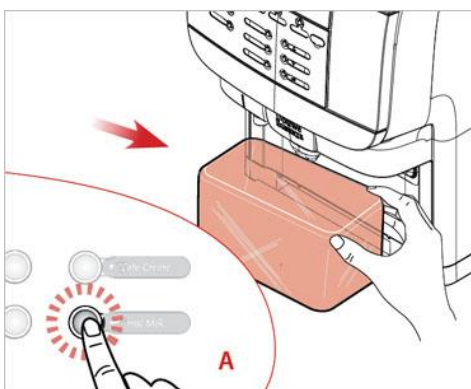

Follow the instruction on the display:
PLACE BIN MIN 1L PRESS ENTER TO CONFIRM

3. Place the container under the drink outlets and press **ENTER**.

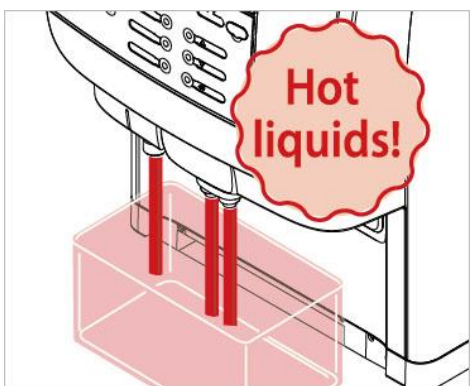

Follow the instruction on the display:
PRESS ENTER TO CONFIRM

4. Press **ENTER** to start flushing all the drink outlets. **CAUTION HOT LIQUIDS** is shown in the display. When done, the dispenser is ready for use.



Warning:

The liquids dispensed by the dispenser are hot! Avoid scalding! Keep hands and other body parts away from the dispenser during the cleaning process.

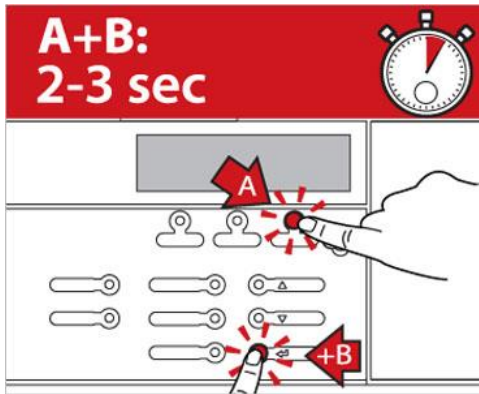

Cleaning

1. Press **STOP** and then **ENTER** button, hold them pressed simultaneously for 2-3 seconds to enter the cleaning mode.
2. The display will show **FLUSHING**, press **UP** or **DOWN** button until display shows **CLEANING**, press **ENTER** to continue.

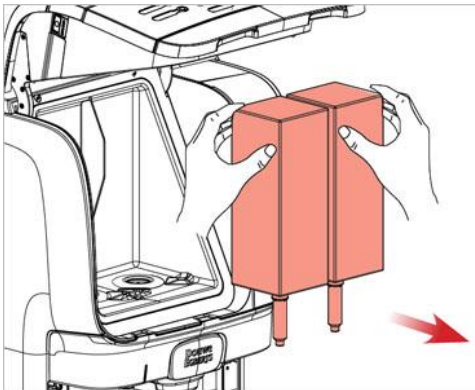

Follow the instruction on the display: **REMOVE PRODUCT PACKS**

3. Open the dispenser door.
4. Remove the product packs.
5. When all packs have been removed the display will automatically continue and show:
CLEAN COOLING BOX PRESS ENTER TO CONFIRM

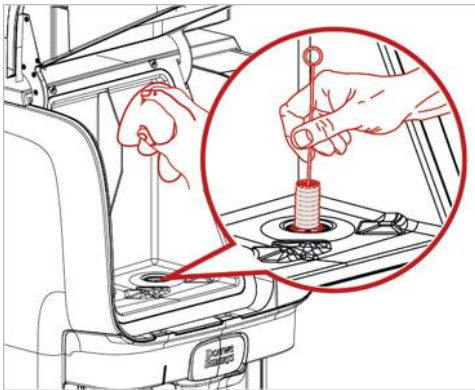

6. Clean the doser opening with a brush and the interior of the cooling compartment with a clean, damp cloth. Dry with a clean paper cloth.

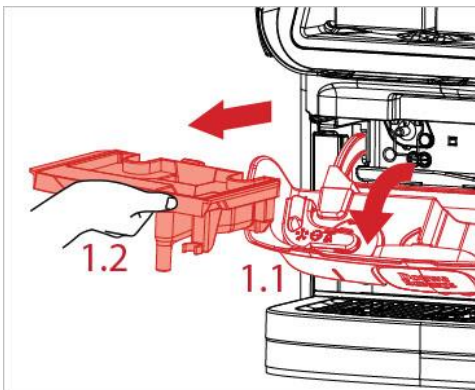

Remove and clean Mixing tray

7. Press **ENTER** and display will show:
REMOVE AND CLEAN MIXING TRAY

8. Follow the steps below:
 - a. Open the water treatment panel (fig.1.1)
 - b. Pull the mixing tray straight out (fig.1.2)



Note:

It is recommended to use the included exchange kit, which consists of clean mixing tray, to save time.

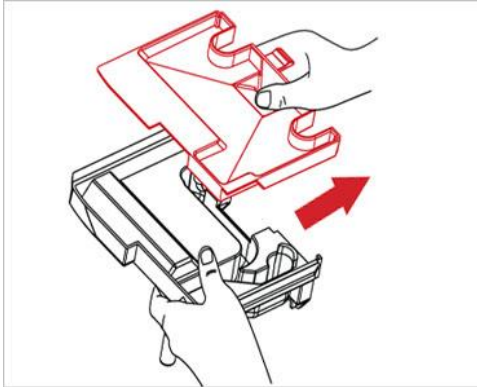

9. Separate the top lid from the base by simply lifting it straight up.

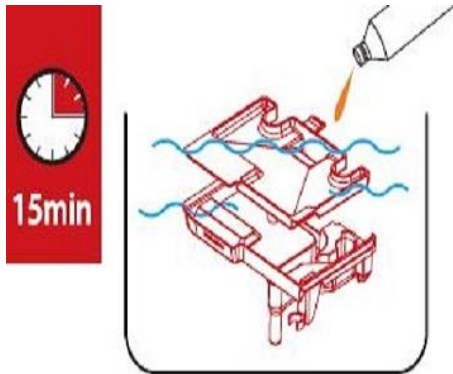

10. Place both parts of the mixing tray in a bin with food grade cleaning agent and hot water and let it soak for approximately 15 minutes.



Note:

Comply with the safety instructions and cleaning instructions on the cleaning agent packaging. The mixing tray can be dished in a dishwasher.

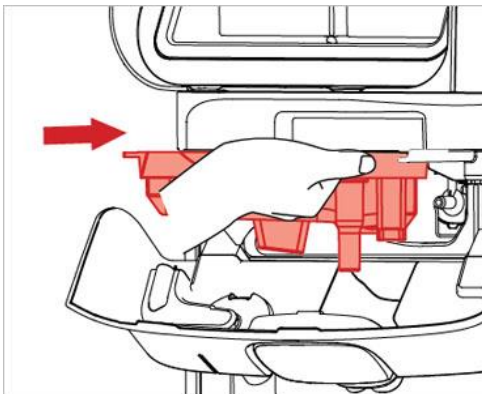

11. Reassemble the top and base of the mixing tray. Display will show: **REINSTALL MIXING TRAY**

Slide the mixing tray back into the machine. Once the mixing tray is in position it will continue to next step.

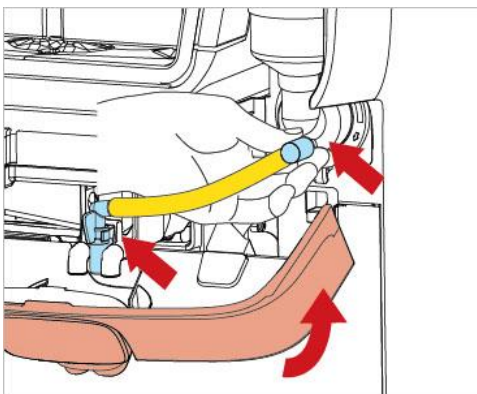

If the machine is fitted with instant option the display will show:

CLEAN MIXER BOWL PRESS ENTER TO CONFIRM



Note:

if the machine don't have instant option it will continue on step 13.

12. To remove and clean the mixer bowl, follow the steps below:

a. Pull out the outlet tube from the mixer bowl.

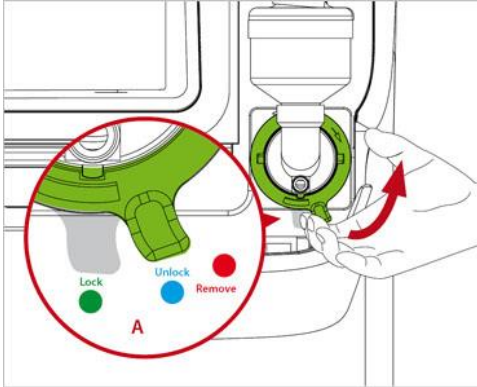

b. turn the mounting plate level anticlockwise into the correct position.

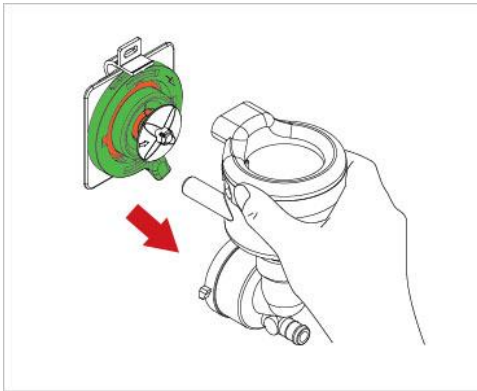

c. Remove the mixer bowl by pulling it straight out.

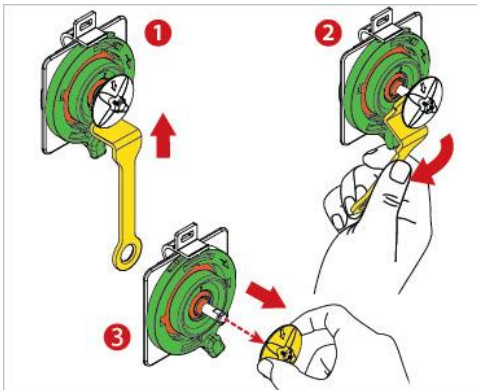

d. Use the included tool to remove the whipper. Place the tool behind the whipper (1). Gently press in the handle towards the machine until the whipper is loose (2). Pull the whipper straight out (3).

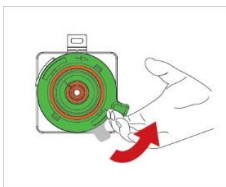

1.

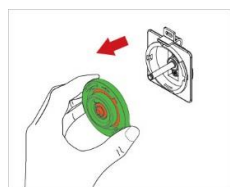

2.

e. Rotate the mounting plate anticlockwise even further until it completely stops (1). Pull the plate straight out (2).

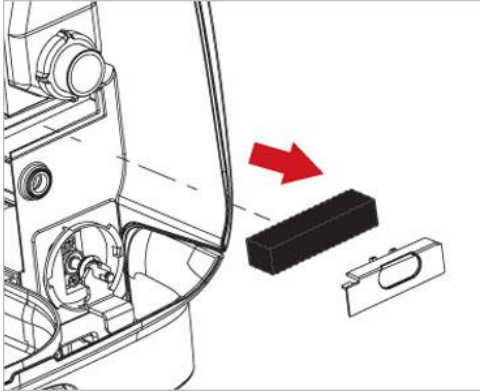

f. Remove the steam trap filter and its cover.

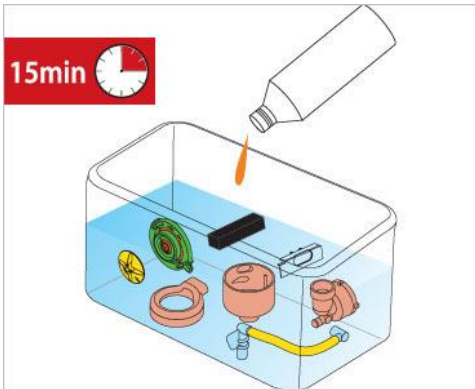

g. Place all the mixer parts in a bin with food grade cleaning agent and hot water and let it soak for approximately 15 minutes.



Note:

Comply with the safety instructions and cleaning instructions on the cleaning agent packaging. The mixer parts can be washed in a dishwasher.

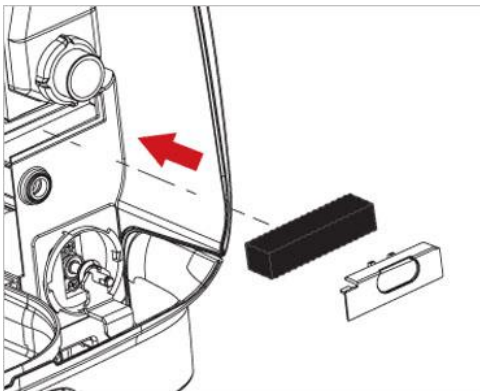

h. Replace the steam trap filter and its cover.

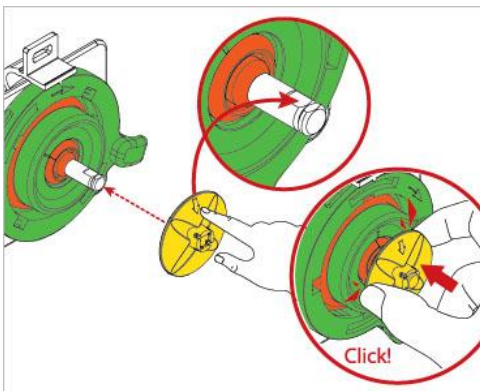

i. Place back the mounting plate on to the mixer motor and shaft. Make sure to align the arrow on the whipper towards the flat surface on the shaft. Press in the whipper until it "CLICK" in to position.

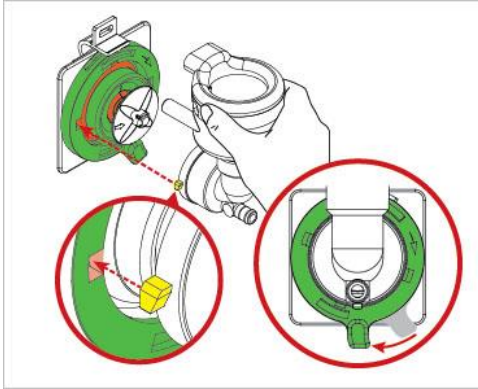

j. Turn the mounting plate clockwise until the holes are in position 9 and 3. Align the guide hooks on the mixer bowl and then push it all the way into position. Finally lock the mixer bowl by turning the mounting plate clockwise until complete stop.

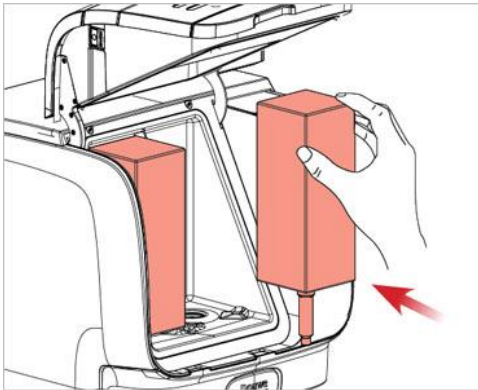

13. Display will show: **REINSTALL WATER TREATMENT PANEL**

Fold up the water treatment panel into position and machine will continue to next step.

14. Display will now show: **PLACE BACK PRODUCT PACKS**

Place the product packs back if they have not passed the expiry date. Else, place new product packs.

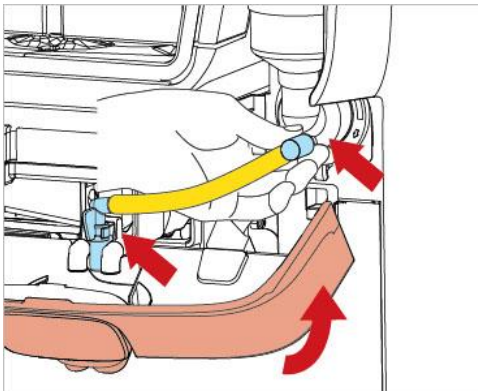

15. When both packs have been placed the display will automatically continue and show:

PLACE BIN MIN 1L PRESS ENTER TO CONFIRM

k. Place back the tube to the mixer bowl, snap in the outlet nozzle on the mixing tray.

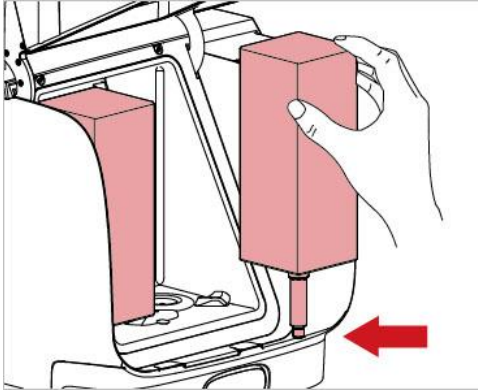

12. Display will show: **REINSTALL WATER TREATMENT PANEL**

13. Display will now show:

PLACE BACK PRODUCT PACKS

Place the product packs back if they have not passed the expiry date. Else, place new product packs.

14. When both packs have been placed the display will automatically continue and show:

PLACE BIN MIN 1L PRESS ENTER TO CONFIRM

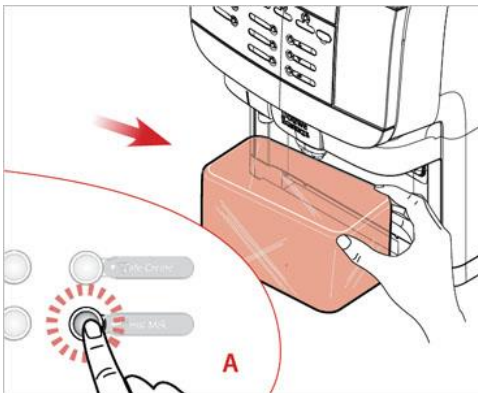

15. Place the flush bin under the product outlets and press **ENTER** button(A).

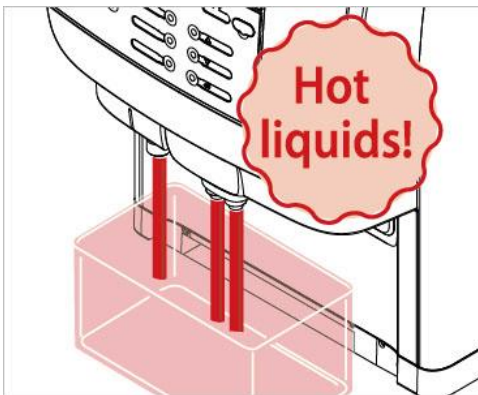

17. Press **ENTER** to start flushing all the drink outlets. **CAUTION HOT LIQUIDS** is shown in the display.

When done, the dispenser is ready for use. Remove flush bin and place the drip tray.



Warning:

The liquids dispensed by the dispenser are hot! Avoid scalding! Keep hands and other body parts away from the dispenser during the cleaning process.

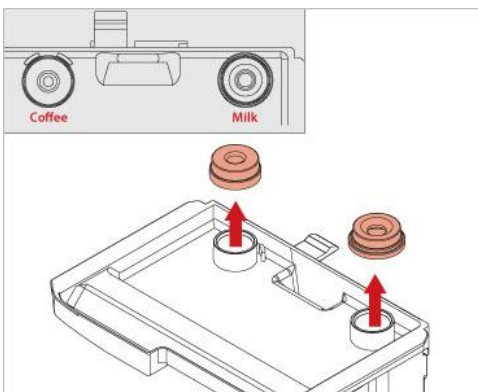

How to disassemble the mixing tray

1. Remove both seals by simply pulling them straight up.

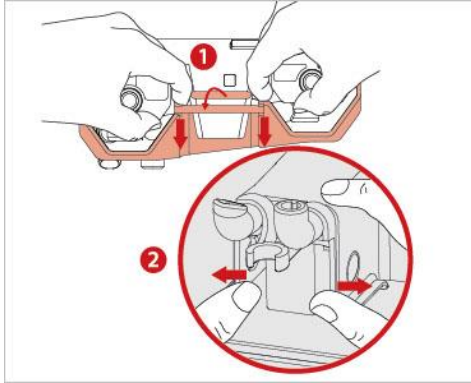

2. Use your fingers to unhook the rib out of its slot on the back side, press it down about 1 cm. (1)

Unhook the front by pressing out the walls around the outlets. (2)

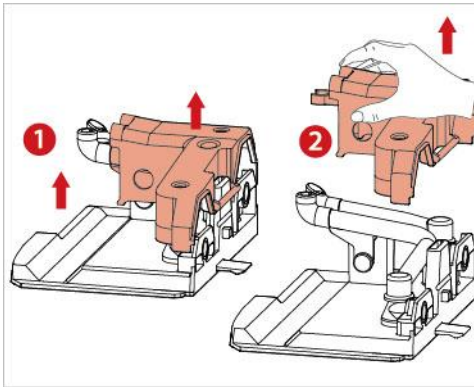

3. Once both back and front is unhooked you can simply pull the cover straight up until it's removed.

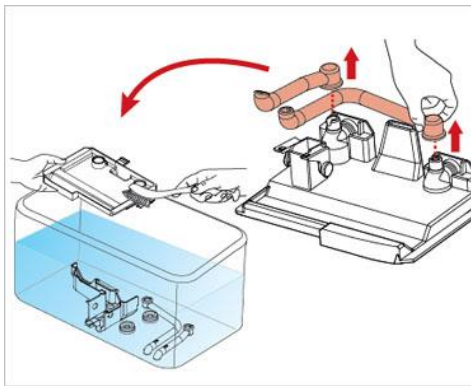

4. Remove the outlets tube from their positions by pulling them straight up.

Place all loose parts in the flush bin with water and clean with a brush.

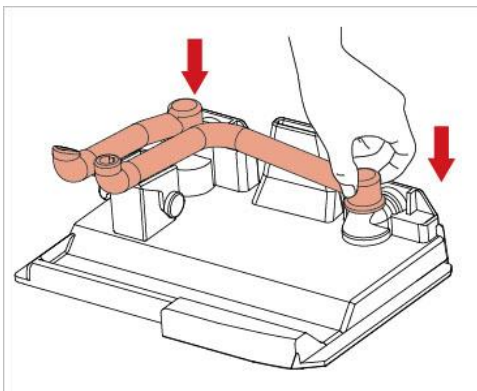

5. After you have cleaned all parts, reassemble the mixing tray in reverse order. Start by placing back the outlet tubes to their mixer chambers.

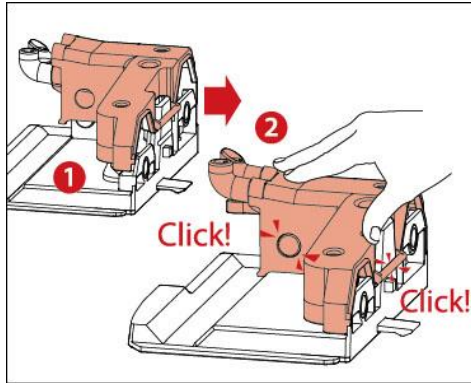

6. Once the tubes are in position, slide back the cover all the way down until the hooks "CLICKS" in at both front and back side.

Check the tips of the outlet tubes so they are aligned properly and not deformed in any way.

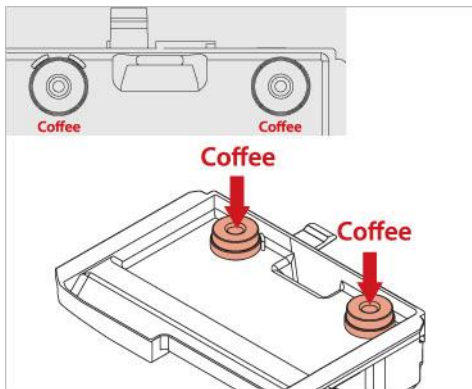

7. Depending how your machine is configured place back the seals according to the pictures. Press them down firmly, swipe your thumb all around the edges on top of the seals to make sure they are in position.

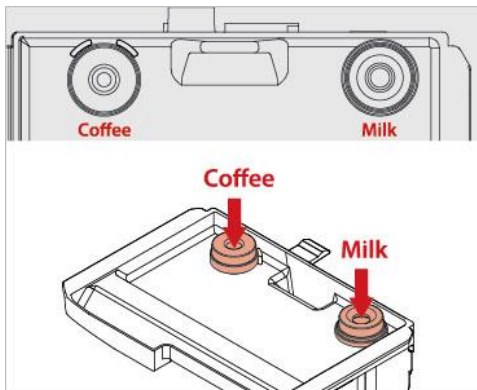

Caution:

The milk seal can only be placed on the right side of the mixer tray. There are ribs on the left side that prevent the milk seal being placed there.

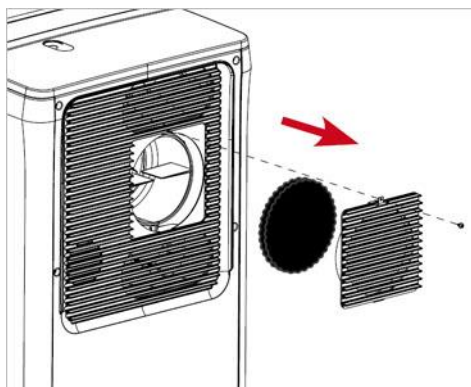

Cleaning the air filter

1. Remove the fixing screw and open the removable ventilation cover to access the foam air filter.



2. Rinse the air filter and cover with warm water to remove any accumulated dust. Squeeze excess water out of the foam air filter and dry the cover with a towel to prevent water getting into the air inlet.

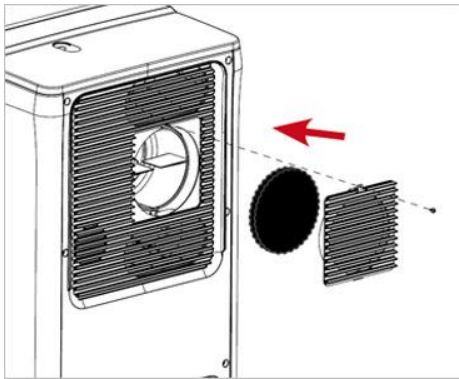

3. Replace the air filter and ventilation cover and reinstall the fixing screw. Do not overtighten the screw.



Note:

The air filter should be cleaned once per month under normal conditions, or twice per month in extremely dusty conditions.

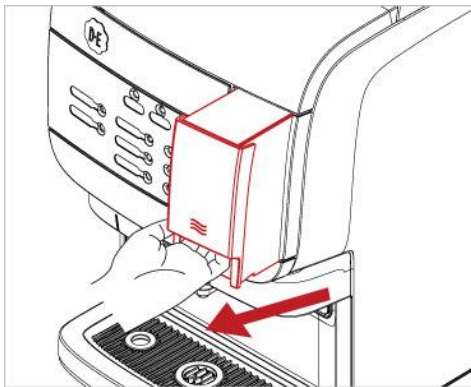

Cleaning the water tank

1. Remove the water tank by lifting slightly, then pulling straight out

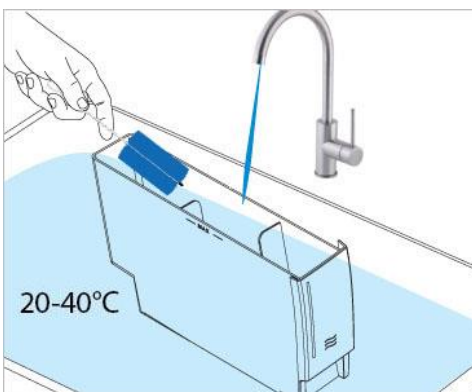

2. Wash the water tank with clean water, 20-40°C / 68-104°F. A food-safe cleaning agent may be used as needed.

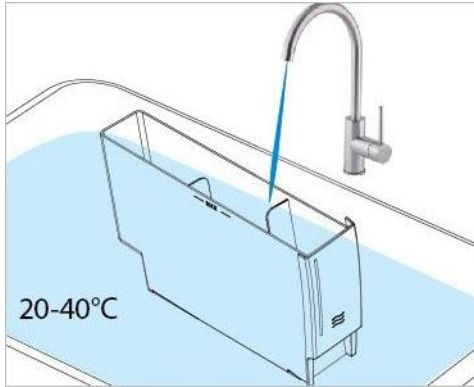

3. Rinse the water tank thoroughly with clean water, 20-40°C / 68-104°F.

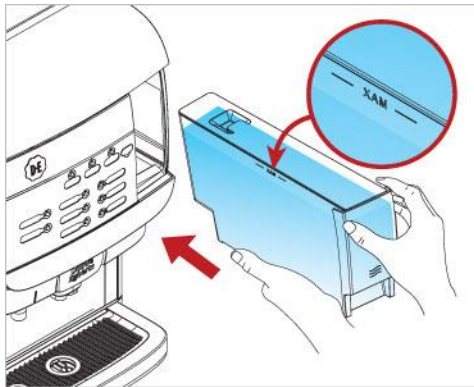

4. Refill the water tank to the MAX level with fresh, clean water and replace it in the dispenser.

User programming

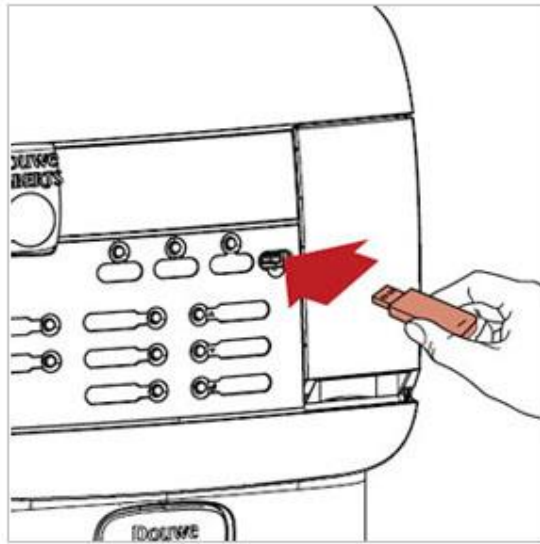

Starting the operator mode

Remove the cover and insert the supplied operator USB key. This immediately starts the operator mode. The first menu item (COUNTERS) is displayed.

The following menus are available:

- COUNTERS - read counters
- VOLUME - change cup volume
- STRENGTH - change drink strength
- DATE / TIME - set date and time
- CLEANING DAYS - set weekdays for cleaning and flushing
- ECO SETTINGS - energy saving mode settings
- TELEPHONE # - enable/disable and set telephone numbers for service and operator.

Please note that menu items might be disabled by the service technician. Contact your Cafitesse systems supplier if you want this altered.

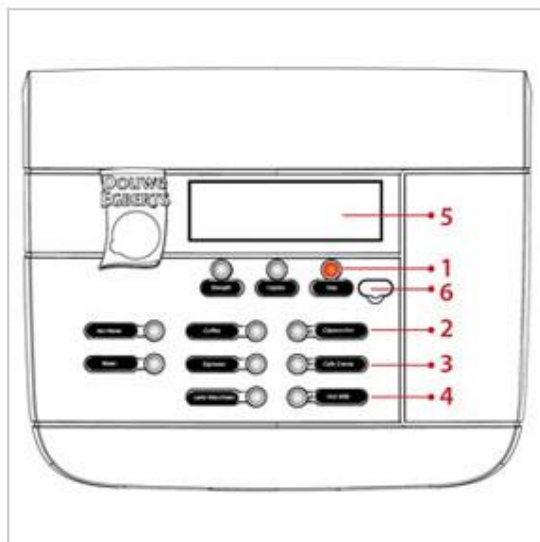

Operator mode controls

1. STOP - go to previous menu (hold for 2 seconds to Return to main menu)
2. Scroll up or increase value
3. Scroll down or decrease value
4. Enter menu
5. Display
6. Port for USB key



Note:
dispenser programming is not available in all markets.

COUNTERS

In the COUNTERS menu, you have various possibilities to read out the drink counters:

- Total number of drinks dispensed
- Subtotals per drink button
- Subtotals VOLUME per drink button
- Total number of HOT drinks

Drink counters

1. Select the COUNTERS menu by using ↑ or ↓ and press ← to access it.

The display will show the total number of drinks:

TOTAL DRINKS

123456

alternating with:

SELECT DRINK

2. Press a drink button to see the total for that specific drink.

The number of deliveries for the selected drink button appears on the display.

Preselection counters

Press the preselection buttons VOLUME or STRENGHT for more detailed counter readings:

- Press the preselection button VOLUME.

The cup icons and the counter reading for the small volume of the selected drink appear on the display.



Note:

If you press the preselection button VOLUME, the display shows counter readings for the small, middle, large, and total drinks.

- Press the preselection button STRENGHT.

The strenght icons and the counter reading for the weak setting of the selected drink appear on the display.



Note:

If you press the preselection button STRENGHT, the display shows counter readings for the weak, normal, strong and total drinks.

- Press STOP to go back one level within the COUNTERS menu.
- Press another drink button to display the respective counter reading for this button.

VOLUME

In the VOLUME menu, you can change the drink volumes for all available drinks at once in the range of +10% to -10%.

1. Select the VOLUME menu by using ↑ or ↓ and press ← to access it.

The following message appears on the display:

VOLUME

+ 8 %

2. Increase or decrease the cup volume using ↑ and ↓ .

3. Confirm the required value with ← . The new cup volume will be accepted immediately.



Note:

If you would like to modify the drink volume again, press ←.

STRENGTH

In the STRENGTH menu, you can change the drink strength for all available drinks at once in the range of +10% to -10%.

1. Select the VOLUME menu by using ↑ or ↓ and press ← to access it.

The following message appears on the display:

Strength

+ 8 %

2. Increase or decrease the drink strength using ↑ and ↓ .

3. Confirm the required value with ← . The new cup volume will be accepted immediately.



Note:

If you would like to modify the drink strength again, press ← .

DATE/TIME

You can set the date and time in the **DATE/TIME** menu.

The time setting needs to be adjusted at the start and end of daylight saving time.

1. Select the DATE/TIME menu by using ↑ or ↓ and press ← to access it.

The date and time settings are shown on the display. The month setting is flashing.

2. Use ↑ or ↓ to select the correct value.

3. Press ← to go to the next field.

4. Repeat steps 1 and 2 for all fields:

MONTH → DAY → YEAR → HOURS → MINUTES

5. When all fields are set you will see the time.



Note:

If the dispenser has been shut down for longer periods, the date and time must be set again.

CLEANING DAYS

You can set the weekdays that you want to clean or flush the dispenser in the CLEANING DAYS menu.

Select the **CLEANING DAYS** menu by using ↑ or ↓ and press ← to access it.

There are two submenus:

- **CLEANING** - set "**Cleaning & Flushing**" days
- **FLUSHING** - set "**Flushing**" days



Caution:

It is mandatory to run the "**Cleaning & Flushing**" program at least once a week to guarantee food safety.

Determine cleaning days

If you have a Coffee-Coffee version, the dispenser only needs to run the "Cleaning" program once a week. Default cleaning day is Monday but you can select any day you prefer.



Note:

You can always set more cleaning and/or flushing days than the minimum required number of days.

Set days for "Cleaning"

1. Use ↑ or ↓ to select the **CLEAN** submenu.

The icon indicates the active weekday(s) for cleaning:

SUN MON TUE WED THU FRI SAT

CLEAN

2. Press ← to enter the submenu.

The icon is displayed, it is positioned under **SUN** (Sunday):

SUN MON TUE WED THU FRI SAT

CL. SET:

3. Use ↑ or ↓ to move the icon to the weekday you would like to select or deselect for cleaning.

4. Press ← to activate or deactivate the selected weekday.

The icon appears under activated weekday(s).



Note:

Several days for cleaning can be set in sequence.

5. Press **STOP** or ← to go back one level within the **CLEANING DAYS** menu.



Note:

"Clean & Flush" is required at least once a week.

Set days for "Flushing"

1. Use ↑ or ↓ to select the **FLUSH** submenu.

The icon indicates the active weekday(s) for flushing:

SUN MON TUE WED THU FRI SAT

FLUSH:

2. Press ← to enter the submenu.

The icon is displayed, it is positioned under **SUN** (Sunday):

SUN MON TUE WED THU FRI SAT

FL. SET:

3. Use ↑ or ↓ to move the icon to the weekday you would like to select or deselect for flushing.

4. Press ← to activate or deactivate the selected weekday.

The icon appears under activated weekday(s).



Note:

Several days for flushing can be set in sequence.

5. Press **STOP** or ← to go back one level within the **CLEANING DAYS** menu.

ECO SETTINGS

You can reduce power consumption by using the menu **ECO SETTING**.

These settings only apply to periods during which the dispenser is not used.

Select the **ECO SETTINGS** menu by using ↑ or ↓ and press ← to access it.

There are four submenus:

- **ECO ENABLE/DISABLE**
- **ECO START**
- **ECO END**
- **ECO TEMPERATURE**



Note:

When the energy saving mode is active, the **ECO** icon is shown on the display of the dispenser.



Note:

The dispenser will become active again when a button is pressed.

Your Cafitesse system supplier can disable this function if you do not want the dispenser to be used while in **ECO** mode.

Enable/disable ECO mode

1. Use ↑ or ↓ to select the ECO ENABLE/DISABLE submenu and press ← to access it. The status is flashing on the display.
2. Use ↑ or ↓ to select ENABLED or DISABLED.
3. Press ← to confirm the selected status.
4. Press STOP or ← to go back one level within the ECO SETTINGS menu.



Note:

By default the ECO mode is enabled between 20.00 & 7.00 hours.

Setting the ECO start and end time



Note:

ECO mode needs to be enabled for the next submenus to show.

1. Use ↑ or ↓ to select the ECO START or ECO END submenu. The current ECO time is shown on the display.
2. Press ← to enter the submenu. The option hour setting flashes and is active.
3. Use ↑ or ↓ to set the correct time (hours).
4. Confirm with ←. The option minutes setting flashes and is active.
5. Use ↑ or ↓ to set the correct time (minutes).
6. Confirm with ←. The new ECO time is shown on the display.

Setting the ECO boiler temperature

ECO mode needs to be enabled for the next submenu to show.

1. Use ↑ or ↓ to select the **ECO TEMPERATURE** submenu. The current ECO boiler temperature is shown on the display.
2. Press ← to enter the submenu. The temperature setting is flashing.
3. Use ↑ or ↓ to select the desired temperature.
4. Confirm with ←. The new ECO boiler temperature is shown on the display.



Note:

Default ECO temperature setting is 63°C / 145.4°F. The lower the ECO boiler temperature is set, the longer it takes for the dispenser to become fully functional again after coming out of ECO mode.

TELEPHONE#

You can set the telephone numbers of operator and service in this menu.

You can also select whether the numbers should be displayed in case:

- cleaning is required (operator)
- a product pack is empty (operator)
- a malfunction is detected (service)

Select the **TELEPHONE #** menu by using ↑ or ↓ and press ← to access it.

The status is shown in the display:

OPERATOR NR: 0123456789

There are four submenus:

- **SHOW OPERATOR NR**
- **SHOW SERVICE NR**
- **OPERATOR NR**
- **SERVICE NR**

Enable/disable telephone numbers

1. Use ↑ or ↓ to select the **SHOW OPERATOR NR** or **SHOW SERVICE NR** submenu and press ←.

The display shows: **Y** (yes) or **N** (no)

2. Use ↑ or ↓ to select **Y** to activate the number display or **N** to deactivate the number display.

3. Confirm with ←.

The new setting will then be shown continuously on the display.

Set telephone numbers

1. Use ↑ or ↓ to select the **OPERATOR NR** or **SERVICE NR** submenu and press ←. The display shows the telephone number. The first digit is flashing: **O: 0123456789**



Note:

O = operator, **S** = service

2. Use ↑ or ↓ to change the first digit.

3. Confirm with ←.



When confirmed the second digit starts flashing: **O: 0123456789**

4. Repeat steps 2 and 3 until all 10 digits are set.

The new telephone number will be shown on the display.

Troubleshooting

You may encounter the following symbols (and messages) in the display.

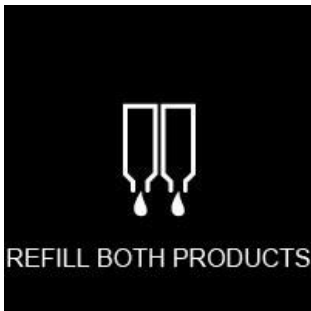
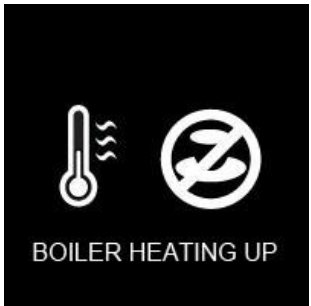
Symbol	Cause	Action
 The symbol shows two ingredient packs on the right side of the dispenser, with the right one being empty. A 'D-E' logo is present. The text 'REFILL RIGHT PRODUCT' is at the bottom.	Empty ingredient pack (right hand side)	Replace the right ingredient pack
 The symbol shows two ingredient packs on the left side of the dispenser, with the left one being empty. A 'D-E' logo is present. The text 'REFILL LEFT PRODUCT' is at the bottom.	Empty ingredient pack (left hand side)	Replace the left ingredient pack
 The symbol shows two ingredient packs, both of which are empty. The text 'REFILL BOTH PRODUCTS' is at the bottom.	The product packs are: 1. empty 2. incorrectly positioned 3. or not present	Replace the empty product packs. Check whether the product pack is inserted correctly. Insert a product pack. Call the operator when the number is shown on the display.
 The symbol shows a thermometer icon and a circular icon with a crossed-out 'Z' (no sleep) symbol. The text 'BOILER HEATING UP' is at the bottom.	The water in the boiler has not yet reached the required temperature.	The drink delivery of the dispenser is blocked until the temperature reaches the correct value.



The drink delivery is blocked because the Standby/Clear-Error button on the dispenser was pressed.

Press the standby/Clear-Error button again to unlock the dispenser.



The dispenser must be cleaned.

Start the cleaning program on the same day. Call the operator if the number is shown on the display.



The drink delivery is blocked because the dispenser was not cleaned as scheduled.

Start the cleaning program immediately. Call the operator if the number is shown on the display.



The water filter of the dispenser must be replaced.

Contact service to replace the water filter.



The drink delivery is blocked because the energy saving mode is switched on.

The ECO mode will end automatically at the set time. (option) Press a drink button. The boiler will start to heat up, once normal temperature is reached you may dispense a drink. The ECO mode becomes active again 10 minutes after the boiler was heated up or the last drink was dispensed.

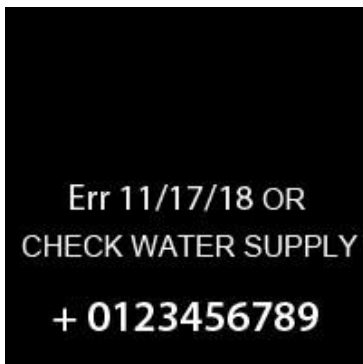

Water system error

Check the water supply line to the dispenser is blocked, open the water tap completely. Press and hold the LOCK/Clear switch for 5 seconds to restart machine. Contact service if the error remains.



Cooling error

Check the ventilation and the ambient temperature of the dispenser, and clean the condensate grid, if necessary. Press and hold the LOCK/Clear switch for 5 seconds to restart machine. Contact service if the error remains.

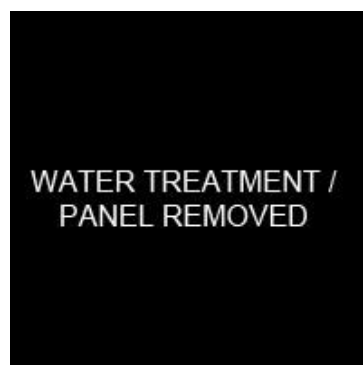

Water treatment panel is not detected

Check if the water treatment panel is in correct place or missing. Contact service if the error remains.



Mixing tray not detected

Check if the mixing tray is in correct place or missing. Contact service if the error remains.



Drip tray is full of water

Remove the drip tray and empty it of water.



Internal water tank is empty

Remove the internal water tank and fill it with fresh tap water, place it back in to the machine and the icons will disappear.

Water leaks from the hot water outlet or a product outlet.

Scale particles block the respective outlet valve, it cannot close completely.

Perform the program "Flushing". Contact service if the problem persists.