

# Bravilor Bonamat<sup>®</sup>

## Operating Instructions

**BOLERO XL**

700.403.290A  
Bravilor Bonamat<sup>®</sup>  
© 01–2001

Bravilor Bonamat  
Pascalstraat 20  
1704 RD Heerhugowaard  
The Netherlands

All rights reserved.

No part of this document may be copied and/or published by means of printing, photocopying, microfilming or by any other means whatsoever without the prior written consent of the manufacturer. This applies equally to the included drawings and/or diagrams.

The information contained in this document is based on general data concerning the construction, materials characteristics and working methods known to us at the time of publication and therefore we reserve the right to make changes without notice. For this reason the instructions given should be regarded as a guide to the installation, use and maintenance of the machine indicated on the front cover.

This document applies to the standard version of this machine. The manufacturer therefore accepts no liability for any damage arising from specifications that deviate from the standard version of the machine as delivered to you.

Every possible care has been taken in the production of this document, but the manufacturer accepts no liability for any errors in this document or for any consequences arising therefrom.

**TAKE THE TIME TO CAREFULLY READ THIS DOCUMENT BEFORE USING THE MACHINE.**

**DURING READING KEEP THE FOLD-OUT OPEN.**

**ALWAYS KEEP THIS DOCUMENT NEAR THE MACHINE.**

# PREFACE

## Using this document

This document is intended to provide instructions for authorized users qualified technicians to safely install, use and maintain and repair the machine.

The words "left", "right", "front" and "back" are used in this document to indicate a particular part of the machine. The point of departure here is the position of the user standing at the operating side.

The position numbers 1.–23. used in this document refer to the figures in the fold-out. On this same sheet the compositions 17. and 22. are specified in more detail. The further elaborated compositions 4. and 18. are dealt with in fig.2 and 3 respectively.

## Icons and symbols

To the **machine** the following safety icons and symbols are applied.



### **WARNING**

△ Risk of electric shock.



### **WARNING**

△ Procedures that can result in serious damage to the machine or in physical injury if they are not carried out with due care.

In this **document** the following icons and symbols can be found:



### **TIP**

– Hint, suggestion or advice to carry out certain tasks more easily or neatly.



### **CAUTION!**

– Procedures that can result in damage to the machine, the surrounding area or the environment if they are not carried out with due care.



### **WARNING**

△ Procedures that can result in serious damage to the machine or in physical injury if they are not carried out with due care.

## Related documents

The following related documents are available:

- Bolero XL maintenance manual

: 700.703.Mxx

## Document code

Document codes consist of two fields:

- Field 1: document number (if required followed by the revision number)
- Field 2: revision date

## Service and technical support

Please contact your dealer for information concerning the specific setting, maintenance or service activities that fall outside the scope of this document. He will always be happy to help you. When doing this, always ensure that you have the following details at hand:

- Model code
- Type number
- Serial number

These data can be found on the identification plate. Write down the data of the identification plate in the intended fields (fig.1 ).

## Guarantee conditions

The guarantee conditions applicable to this machine form part of the terms of delivery.

## Identification of the machine

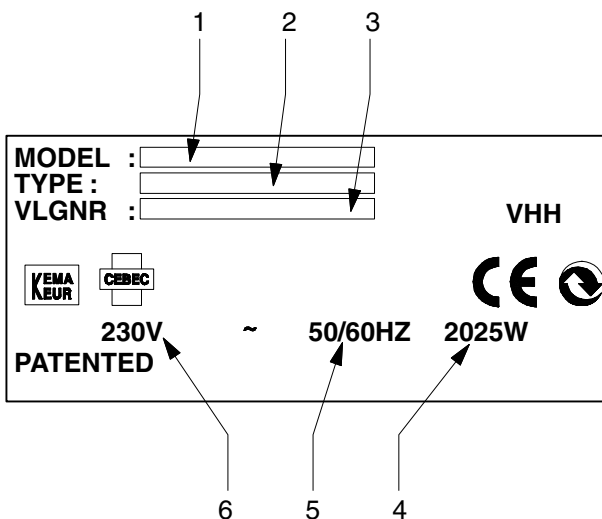

Fig. 1 Identification plate

1. Model code
2. Type number
3. Serial number
4. Output capacity
5. Frequency
6. Supply voltage

# Table of contents

<b>Preface</b> .....	<b>I</b>
<b>Using this document</b> .....	<b>I</b>
Icons and symbols .....	I
Related documents .....	I
Document code .....	I
Service and technical support .....	II
Guarantee conditions .....	II
<b>Identification of the machine</b> .....	<b>II</b>
<b>Safety instructions and danger warnings</b> .....	<b>VI</b>
General .....	VI
Instructions for use .....	VI
Icons and instructions on the machine (if present) .....	VI
Users .....	VI
Proper use .....	VI
Technical specifications .....	VI
Modifications .....	VI
Installation .....	VII
Use .....	VII
Maintenance and repairing failures .....	VII
Safety devices present .....	VIII
<b>Machines and the environment</b> .....	<b>VIII</b>
Packaging material .....	VIII
Disposal of the machine .....	VIII
<b>1. Introduction</b> .....	<b>1</b>
<b>1.1 General description</b> .....	<b>1</b>
<b>1.2 Main components</b> .....	<b>1</b>
1.2.1 Outside .....	1
1.2.2 Inside .....	1
<b>2. Technical data</b> .....	<b>2</b>
<b>2.1 General</b> .....	<b>2</b>
<b>2.2 Dimensions</b> .....	<b>2</b>
<b>2.3 Electrical system</b> .....	<b>2</b>
<b>2.4 Water system</b> .....	<b>2</b>
<b>2.5 Capacity</b> .....	<b>2</b>
<b>2.6 Environmental conditions</b> .....	<b>2</b>
<b>2.7 Recommended descaling materials</b> .....	<b>2</b>
<b>3. Installation</b> .....	<b>3</b>
<b>3.1 Unpacking</b> .....	<b>3</b>
<b>3.2 Installation</b> .....	<b>3</b>
<b>3.3 Initial use</b> .....	<b>4</b>
3.3.1 Drink system .....	4
3.3.2 Hot water system .....	4
<b>4. Operation</b> .....	<b>5</b>
<b>4.1 Controls</b> .....	<b>5</b>
4.1.1 Operating panel front .....	5
4.1.1.1 Display .....	5
4.1.1.2 Buttons and keys .....	5
4.1.2 Operating panel inside .....	5
4.1.2.1 Electronic control .....	5
4.1.2.2 Keys on the electronic control .....	5

<b>4.2</b>	<b>Daily use</b> .....	<b>6</b>
4.2.1	Tap cup .....	6
4.2.2	Tapping mug, half a jug or whole jug .....	6
4.2.3	Indicator 'drip-tray full' .....	6
4.2.4	Raising the machine .....	6
<b>5.</b>	<b>Maintenance by users with limited authority</b> .....	<b>7</b>
<b>5.1</b>	<b>Daily</b> .....	<b>7</b>
5.1.1	General .....	7
5.1.2	Checking the supply in the ingredients container .....	7
5.1.3	Cleaning .....	7
5.1.3.1	Rinsing programme .....	7
5.1.3.2	Cleaning the mixing system .....	8
<b>5.2</b>	<b>Weekly</b> .....	<b>8</b>
5.2.1	General .....	8
5.2.2	Cleaning outside .....	8
5.2.3	Cleaning the mixer and the supporting plate .....	8
5.2.4	Cleaning ingredients container .....	9
<b>6.</b>	<b>Use of the programming unit</b> .....	<b>10</b>
<b>6.1</b>	<b>Reading out the counter contents or re-setting the counter</b> .....	<b>10</b>
6.1.1	Reading counter positions of tapped drinks .....	10
6.1.2	Reading counter positions per drink .....	10
6.1.3	Resetting the counter positions to zero .....	10
<b>6.2</b>	<b>Setting possibilities</b> .....	<b>10</b>
6.2.1	Setting the amount of water per drink .....	10
6.2.2	Switching on or off the tapping possibilities 'mug, half a jug or whole jug' ...	11
6.2.2.1	Switching off .....	11
6.2.2.2	Switching on .....	11
6.2.3	Setting strongness of drink .....	12
6.2.4	Setting the hot water temperature .....	12
6.2.5	Setting descaling signal .....	13
<b>7.</b>	<b>Maintenance by authorized users</b> .....	<b>14</b>
<b>7.1</b>	<b>Descaler</b> .....	<b>14</b>
<b>7.2</b>	<b>Cleaning the exhaust fans</b> .....	<b>15</b>
<b>8.</b>	<b>Correcting malfunctions</b> .....	<b>16</b>
<b>8.1</b>	<b>Malfunctioning analysis general</b> .....	<b>16</b>
<b>8.2</b>	<b>Display messages and their meanings</b> .....	<b>17</b>
<b>9.</b>	<b>Consumable items and accessories</b> .....	<b>18</b>
<b>9.1</b>	<b>Recommended consumable items</b> .....	<b>18</b>
<b>9.2</b>	<b>Accessories</b> .....	<b>18</b>
9.2.1	Raising feet .....	18

## Table of figures

---

Fig. 1 Identification plate .....	II
Fig. 2 Operating panel front .....	5
Fig. 3 Operating panel inside .....	5
Fig. 4 Flushing programme .....	7
Fig. 5 Positioning of the outlets .....	8
Fig. 6 Mounting the mixer .....	8
Fig. 7 Counter positions .....	10
Fig. 8 Initial situation programming .....	11
Fig. 9 Setting the amount of drink .....	11
Fig. 10 Initial situation programming .....	12
Fig. 11 Strongness drink .....	12
Fig. 12 Temperature setting .....	12
Fig. 13 Descaling signal .....	13
Fig. 14 Descaling signal .....	14
Fig. 15 Descaling programme .....	14
Fig. 16 Removing the fan grille .....	15
Fig. 17 Removing the fan blade .....	15
Fig. 18 Raising foot .....	18

---

## Safety instructions and danger warnings

### General

The manufacturer accepts no liability whatsoever for damage or injury resulting from a failure to (strictly) observe the safety instructions contained in this document or resulting from negligence during the installation, use or maintenance of the machine specified on the front cover of this document or of any related accessories.

Additional safety instructions may be required, depending on the specific working conditions required for the accessories used. Please contact your dealer if you think there may be any potential danger in using the machine.

**The full responsibility for observing the local safety instructions and regulations always rests with the user of the machine.**

### Instructions for use

- Each person working with the machine should know the contents of this document and carefully follow the instructions contained. The management must instruct the personnel on the basis of this document and take all the instructions and recommendations into account.
- Never change the order in which activities must be carried out.
- Always keep this document near the machine.

### Icons and instructions on the machine (if present)

- Icons, warnings and instructions attached to the machine form part of the safety provisions. They must not be covered or removed and they must be present and remain legible throughout the life of the machine. Any icon, warning or instruction that becomes illegible must be repaired or replaced immediately.

### Users

- The machine may only be used by properly trained and authorized persons. Temporary staff and persons undergoing training may only use the machine under the supervision and responsibility of authorized users.

### Proper use<sup>1</sup>

The machine is exclusively made for delivering various hot drinks and hot water. Any other or further use is not in conformity with the purpose. The manufacturer does not accept any liability for damage or injury resulting from this. The machine meets the current standards and guidelines. Use the machine only if it is in perfect technical condition and only for the proper purpose as described above.

### Technical specifications

The specifications given in this document may not be modified.

### Modifications

Modification of (parts of) the machine is not allowed.

1. "Proper use" as laid down in EN 292-1 is the use for which the technical product is suitable as stated by the manufacturer – including any instructions in the sales brochure. In cases of doubt, it is the use that is evident from the construction, version and function of the product. Proper use includes taking into account the instructions included in the "instructions for use".

---

## Installation

- The maximum acceptable ambient temperature with which a good operation can be guaranteed is 40°C.
- Consider damage caused by freezing. Never place the machine in rooms in which the temperature can drop below 0°C. After all, with normal use there will always be water in the machine.
- Do not turn over the machine, move it upright.
- Never install the machine in places where water is sprayed or sprinkled.
- Never install the machine in front of entrances, exits or passageways intended for emergency services.
- Place the machine on a sufficiently solid, flat surface close to a water connection, water discharge and an earthed electrical power outlet.
- Connect the machine to the electrical supply in such a way that the power can easily be disconnected.
- Leave sufficient space at the back and front of the machine for maintenance and repair purposes.
- Leave a space of at least 5 cm at the left and right sides of the machine for ventilation.
- Connect the machine to a readily accessible, manually operated water tap, so that the water supply can easily be turned off.
- Always observe local rules and standards when installing this machine.

## Use

- Inspect the machine before use and check for damages.
- Protect the machine against water and moisture. Do not wet the machine by spraying and never submerge the machine in water.
- Keep the operating controls free from dirt and grease.
- Note that during use some parts of the machine become very hot.
- Disconnect the electricity grid and the water supply when the machine will not be used for a longer period. Clean the machine following the instructions in chapter 5. Make sure that no ingredients are left in the ingredient containers. Discharge the water (chapter 7.).
- Components that need lubrication and come into contact with the drink may only be lubricated with silicone grease suitable for food products.

## Maintenance and repairing failures

- Repair and maintenance activities not included in this document must always be carried out by service mechanics.
- If the mains lead is visibly damaged, it has to be replaced by a qualified service technician.
- Observe the given maintenance intervals. Overdue maintenance can lead to high repair costs and may cause guarantee claims to become invalid.
- Do not carry out any maintenance activities concerning the machine before having it protected against unintentional coming into operation. In such cases disconnect the electricity grid.
- Avoid contact with moving parts.
- Never leave the machine during maintenance activities.
- For cleaning the machine only use descaler recommended by the manufacturer.
- Always wear suitable facial protection and gloves while working with descaling materials. Wash your hands after using these materials.
- Prevent damage of the machine caused by spilled descaler solution. Remove spilled solution as quickly as possible and follow the previously mentioned safety instructions.

---

## Safety devices present

The machine is default provided with the following safety devices:

- Using the ON/OFF–switch the machine is switched on or off. After switching off there is still some residual voltage in the electrical system. Remove the plug from the wall outlet in order to take away this residual voltage.
- Electrical fuse of electronic components that is activated as soon as the power drop exceeds the allowed maximum value due to a power failure.
- Thermal safety device that interrupts the power when the water temperature in the boiler becomes too high.
- Boiling protection that interrupts the power when the boiler temperature becomes too high.
- Overflow protection that prevents the machine from taking in more water than allowed.
- Emergency stop to interrupt a selection of the amount of fluid (cup, half a can or whole can). The cycle started last is finished.
- Drip–tray with float indication and discharge possibilities to prevent trouble caused by spilled drink.

## Machines and the environment

### Packaging material

The main components of the packaging material for transport and protection of the machine are the following:

- Corrugated board
- Polystyrene elements

Generally, the packaging material can be returned through your dealer after installation of the machine. If this is not be possible, ask your local authority refuse department how you can dispose of the materials.

### Disposal of the machine

Machines that you wish to dispose of can usually after consultation be returned to your dealer. If this is not possible, inquire with your local authority about the possibilities for re–use or environmentally–friendly processing of the materials. All plastic parts have been clearly coded for this purpose. The printed–circuit board in the machine and the components connected to this should be consigned to electrical or electronic refuse.

---

# 1. INTRODUCTION

## 1.1 General description

This is a hot drinks machine designed for serving various hot drinks and hot water. The functions of the machine are fully computer-controlled. The personnel responsible for the operation can change the factory settings in the programmable control. Once programmed and set conform the specific wishes and requirements, the machine can be easily operated by the consumer through the operating panel (with display) at the front.

## 1.2 Main components

The machine consists of the following main components (see the fold out):

### 1.2.1 Outside

1. Lid
2. Door
3. Window + text plate
4. Operating panel front
5. Hot water outlet
6. Drink outlet
7. Drip-tray plate
8. Drip-tray
9. Indicator 'drip-tray full'
10. Foot (4x)
11. Lock
12. Identification plate
13. Water connection
14. Ventilation grille
15. Mains cable

### 1.2.2 Inside

16. ON/OFF switch
17. Ingredient containers 1 – 4
  - 17.1 Lid
  - 17.2 Ingredients container
  - 17.3 Outlet (discharge opening)
  - 17.4 Fixing cam
  - 17.5 Worm (plastic) or spiral (metal)
  - 17.6 Drive clutch
  - 17.7 Agitator
18. Operating panel inside
19. Drink outlet
20. Fixing hole for drip tray
21. Drain hose
22. Mixing unit (2x)
  - 22.1 Exhaust hood
  - 22.2 Mixing basin
  - 22.3 Outlet piece
  - 22.4 Drink outlet hose
  - 22.5 Mixing room
  - 22.6 Mixer
  - 22.7 Supporting plate
23. Pouring opening descaler

## 2. TECHNICAL DATA

### 2.1 General

Model : Blr42-001  
Weight (empty) : 15,1 kg

### 2.2 Dimensions

- See the fold out.

### 2.3 Electrical system

- See the identification plate for the correct values.

### 2.4 Water system

Water hardness : min. 5 °dH  
Min. water pressure (supply) : 100 kPa (1 bar)  
Max. water pressure (supply) : 1000 kPa (10 bar)  
Flow-rate : 2 l/min  
Conductivity : ≥ 35 µ Siemens/cm  
Boiler capacity : 1 liter  
Hour capacity (hot water) : 20 liters per hour

### 2.5 Capacity

Start-up time : 2 minutes  
Delivery time per cup (120 ml) : 6 seconds

### 2.6 Environmental conditions

In view of danger of freezing the machine may never be placed in rooms where the temperature can fall below 0°C.

### 2.7 Recommended descaling materials

Descaler : RENEGITE



#### **CAUTION!**

- Before use first read the instructions on the packing.

See chapter 9. for ordering descaler.

## 3. INSTALLATION

### 3.1 Unpacking

- Check whether the machine is complete. The contents of the packaging consist of:
  - 1 hot drinks machine
  - 1 drip-tray (complete with drip-tray plate)
  - 1 water connection hose
  - 1 sachet of RENEGITE descaler
  - 1 funnel (for descaling)
  - 1 scrubbing brush for cleaning the ingredients container
  - 2 door keys
  - 1 glass jug
  - supplementary sheet with factory settings
  - This manual
- Please contact your dealer if components are missing or damaged.

### 3.2 Installation

- Place the machine on a flat (max. 5° off plumb), sufficiently solid surface near a water connection point (and if possible a water discharge) and an electricity connection point **that is earthed**.
- Leave sufficient space for maintenance and repair purposes at the back and front of the machine.
- Leave a space of at least 5 cm at the left and right sides of the machine for ventilation.
- Connect the machine to a readily accessible manually operated water tap, so that the water supply can easily be turned off. Use the water connection hose provided for this.
- Open the tap.
- Open the door (2.) on the left side with the key.
- Swing up the cover (1.) of the machine.
- Remove the cover (17.1) of the 1<sup>st</sup> ingredients container. Fill the ingredients container with the ingredient especially meant for this machine, according to table 2 on the supplementary sheet.
- Put back the cover on the ingredients container.
- Also fill the other containers with the correct ingredient, according to table 2 on the supplementary sheet.

#### **WARNING**

△ Power supply voltages vary from one country to another. Ensure that the machine is suitable for connecting to the local power supply. Details on the required supply voltage and frequency can be found on the identification plate.



Follow the instructions below to install another language with drink names:

- Remove the window (3.) with the name plate.
  - Press the plastic lips of the window from the inside of the machine to the outside.
  - Remove the window and the name plate.
- Place the multilingual, double-sided leaf with drink names behind the name plate. Now you can read the drink names in the required language through the openings.
- Remount the window with the name plate.
- Connect the plug to the power socket.
- Switch the machine on by turning the ON/OFF switch (16.) to ON. A little red square appears on the switch. The machine starts filling up with water. On the display all fields light up for a moment).
- Close the cover (1.) and close the door (2.) with the key. When the water is hot enough, the flashing thermometer disappears.



## **TIP**

- It is possible to mount a discharge hose on the drip-tray. At the back of the drip-tray there is a spout. Bore a hole in this and slide the hose on.
- Hook the fixing cam of the drip tray into the fixing hole (20.).

## **3.3 Initial use**



## **CAUTION!**

- Inspect the machine before use and check for damages.
- Protect the machine against water and moist. Do not wet the machine by spraying and never submerge it in water.
- Keep the operating controls free from dirt and grease.
- Note that during use some parts of the machine become very hot.

At coming into operation the machine has the default factory settings. If required, these settings can be adjusted (chapter 6.).

## **3.3.1 Drink system**

- Place an empty cup under the drink outlet (6.).
- Press the Selection button of the drink to be tested.
  - The selection is confirmed by a beep. Only the dot on the display at the selected drink remains after which the drinks flows into the cup. During the filling the cup on the display flashes.
- Throw away the content of the first two cups.
- Check for the 3<sup>rd</sup> cup whether the taste and the amount are right. If not, correct the taste and/or amount (§6.2).
- Repeat the above steps for the other drinks.

## **3.3.2 Hot water system**

- Place an empty cup under the hot water outlet (5.).
- Press the Selection button (4.10) 'hot water'.
  - The selection made is confirmed by a beep. Only the dot on the display at the selected drink remains after which the water flows into the cup. During the filling the cup on the display flashes.

The system is now ready for use.

## 4. OPERATION

### 4.1 Controls

The machine is provided with two operating panels, one at the front (fig.2 ) and one at the inside (fig.3 ). During normal daily use of the machine by the consumer, only the operating panel at the front is used. For programming and specific activities the operating panel at the inside is important as well.

#### 4.1.1 Operating panel front

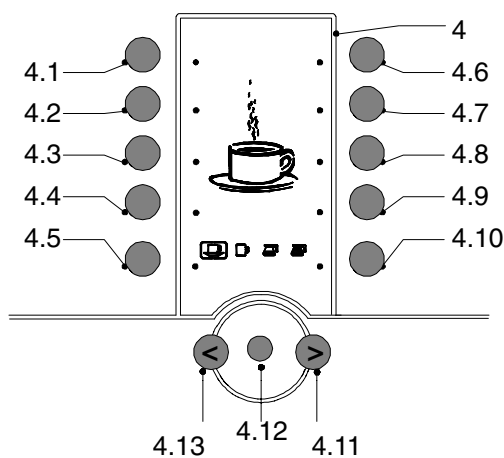

Fig. 2 Operating panel front

##### 4.1.1.1 Display

- The display (4.) shows during normal use while programming, rinsing or descaling the machine and in the case of failures various symbols, values and messages that will be explained in this manual. Fig.2 displays the basic position (operational position).

##### 4.1.1.2 Buttons and keys

- 4.1– 4.9 Selection buttons for various hot drinks
- 4.10 Selection button 'hot water'
- 4.11 Setting key [>]
- 4.12 Enter key (blocked during normal use of the machine)
- 4.13 Setting key [<]

The setting keys (4.11 and 4.13) have more than one function. During normal use of the machine these keys are only used to choose between cup, mug, half a jug and whole jug respectively).

The [Enter] key (4.12) is blocked during normal use of the machine.

#### 4.1.2 Operating panel inside

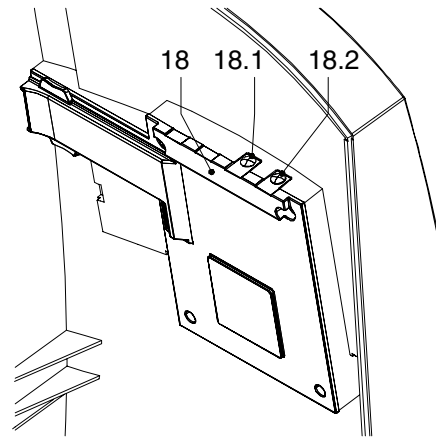

Fig. 3 Operating panel inside

##### 4.1.2.1 Electronic control

The housing of the electronic control with operating panel (18.) of the machine is found at the inside of the door (2.). The two keys are for service and maintenance activities.

##### 4.1.2.2 Keys on the electronic control

18.1 Key 'rinse'

18.2 Programming key

While the machine is in use, the factory default settings may appear to be incorrect or insufficient for the situation in which the machine is used. These settings can be adjusted following the instructions in §6.2.

The present chapter (4.) therefore only describes the normal daily use of the machine.

Periodic maintenance by users with limited authority is described in Section 5.

## 4.2 Daily use

- Switch the machine on with the ON/OFF switch (16.) under the cover (1.). When the machine is on there is a little red square visible on the switch. During warming up a flashing thermometer appears in the upper right corner of the display. Tapping is only possible after the thermometer has disappeared from the display.

### 4.2.1 Tap cup

You can only select those drinks that are indicated on the display by a black dot.

- Place an empty cup under the drink outlet (6.).
- Select a drink with one of the selection buttons (4.1 – 4.9).
  - The selection made is confirmed with a beep. On the display only the dot with the selected drink remains after which the drink flows into the cup. During the filling the cup flashes on the display.

### 4.2.2 Tapping mug, half a jug or whole jug



#### TIP

- After 5 seconds the setting automatically returns to tapping a cup.
- Tapping a half or whole jug is **not possible for all drinks** (this depends on the type of the machine)
- Select with the setting key (4.11 or 4.13) mug, half a jug or whole jug.



#### TIP

- If a thermometer appears on the display the temperature is (temporarily) too low caused by tapping too much water. The machine is blocked until the temperature is right again.
- Place an empty mug or jug under the drink outlet (6.).
- Select a drink with one of the selection buttons (4.1 – 4.9).
  - The selection made is confirmed with a beep. On the display only the dot with the selected drink remains after which the drink flows into the mug or jug. During the filling the cup flashes on the display.

#### TIP

- By pressing any selection button after having selected a mug, half a jug or a whole jug you prevent the machine from really executing this task. The machine is now limited to tapping just one cup.



### 4.2.3 Indicator ‘drip-tray full’

The float indication (9.) will come up at reaching the maximum level of spilled drink. In this case, empty the drip-tray as soon as possible!

### 4.2.4 Raising the machine

When you use a mug or jug that **does not fit under the drink outlet** you can temporarily remove the drip-tray.

If necessary, the machine can be raised 2 cm with a set of raising feet to increase the distance between the drink outlets and the drip-tray. Such a set can be ordered as accessory with your specialist (§9.2.1).

## 5. MAINTENANCE BY USERS WITH LIMITED AUTHORITY

### 5.1 Daily

#### 5.1.1 General

Obviously, the machine and the accessories must be carefully kept clean. Besides, it should be checked daily whether there are still sufficient ingredients in the ingredient containers.

- Remove the drip tray (8.) complete and wash all components in hot water with a normal washing-up liquid.



#### **WARNING**

△ Take action if the descaler signal appears in the display (fig.13 ).

#### 5.1.2 Checking the supply in the ingredients container

- Open the door (2.) with the supplied key.
- Lift up the cover (1.).
- Check the contents of the ingredient containers (17.).

##### Filling up:

- Lift the ingredients container (17.) a bit slantingly backwards out of the machine.
- Remove the cover (17.1).
- Check whether the ingredients have not congealed. If this is the case, clean the ingredients container (§5.2.4).
- Fill up the corresponding ingredient, see supplementary sheet table 2 .
- Press the cover on the container and place this back into the machine. Make sure that the drive clutch (17.6) at the back side of the container is slid over the drive shaft in the back wall and that the fixing cam (17.4) at the bottom falls into the notch of the sheet-metal work.



#### **WARNING**

△ The ingredient containers and their places in the machine are numbered. Always stick to the order of the numbers.



#### **TIP**

– The ingredients container can also be filled without taking it out of the machine.

#### 5.1.3 Cleaning

##### 5.1.3.1 Rinsing programme

The machine has a rinsing programme to clean the mixing units. It is recommended to run this programme daily.

- Place a jug under the drink outlet (6.).
- Press key (18.1) at the inside of the door.

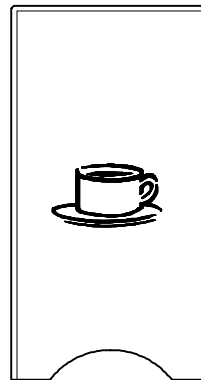

Fig. 4 Flushing programme

A flashing cup appears on the display to indicate that the rinsing programme is active.

- Repeat the rinsing by pressing the key (18.1) again until the water coming out of the drink outlet piece is clean.
- Close the door with the key and place the drip-tray in front of the machine again.

## 5.1.3.2 Cleaning the mixing system

- Remove the drip tray (8.).
- Open the door (2.).
- Tilt the ingredient containers a bit slantingly backwards and lift them out of the machine.
- Pull the mixing basin (22.2) towards you, so that the exhaust opening of the exhaust hood (22.1) is released and subsequently move it back and forth to remove the exhaust hood.
- Pull the mixing basin (22.2) carefully loose from the water connection and remove it by moving it back and forth.
- Pull the outlet hose (22.4) carefully loose from the mixing room (22.5).
- Turn the outlet piece (with hose) (22.3) a quarter of a turn into the direction of the machine and then move it upwards, so that it is loosened from the drink outlet.
- Remove the mixing room (22.5) by turning it to the right and after that pulling it towards you.
- Repeat this procedure for the other mixing unit.
- Wash all components in hot water with a normal washing-up liquid.
- Remount all parts in reversed order.



### **WARNING**

- Turn the outlets apart; they should touch the side of the mixing basin.

## 5.2 Weekly

### 5.2.1 General

The following activities must be carried out weekly:

### 5.2.2 Cleaning outside

- Remove the drip-tray (8.).
- Wash all part of the drip-tray in hot water.
- Clean the outside of the machine with a moist cloth. If necessary use a non-scratching or non-corrosive cleaning product.
- After this dry the machine with a soft cloth.
- Place the drip-tray (8.) in front of the machine again.

### 5.2.3 Cleaning the mixer and the supporting plate

- Carry out the first 8 steps of §5.1.3.2.
- Remove the mixer (22.6) from the mixer motor shaft by pulling it perpendicularly from the shaft.
- Remove the supporting plate (22.7) by turning it to the right and after that pulling it towards you.
- Repeat this procedure for the other mixing unit.
- Wash all components in hot water with a normal washing-up liquid.
- Remount all parts in reversed order.

### **TIP**

- At mounting the mixer in the mixer motor shaft the dot (fig.5 ) must be in line with the flattened part of the mixer motor shaft.

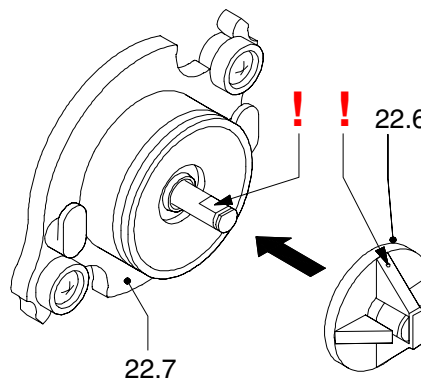

Fig. 5 Mounting the mixer

## 5.2.4 Cleaning ingredients container

- Lift the ingredients container slantingly backwards out of the machine.
- Remove the cover (17.1).
- Shake the ingredients out of the container into a clean dry bowl.
- Take the outlet (17.3) away.
- Remove with the supplied scrubbing brush the remnants from the ingredients container, from the worm (or spiral) (17.5) and from the outlet.



### **TIP**

- If necessary, the large nuts at the front and at the back can be loosened. The loose components can be cleaned with hot water.



### **WARNING**

△ If you clean the ingredients container with water, make sure that all parts are very dry before you fill the ingredients container again. This prevents encrusting.

- Fill up the corresponding ingredient, see supplementary sheet table 2 .
- Press the cover (17.1) and the outlet (17.2) on the ingredients container (17.) and **on the correct place** back into the machine. Make sure that the drive clutch (17.6) at the back side slides over the drive cam in the back wall. Make sure that the fixing cam (17.4) at the bottom falls into the notch of the sheet-metal work.
- Repeat this procedure for the other ingredient containers.

### **TIP**

- Check before using the machine again whether all parts have been mounted correctly:
  - Are the ingredient containers (17.) at the right place and is the fixing cam (17.4) at the bottom side of the notch of the sheet-metal work?
  - Have the outlet pieces (17.3) of the ingredient containers been placed correctly above the left and right mixing units?
- Reflush the mixing units (§5.1.3.1) because ingredients may have fallen into the mixing units during placing the ingredient containers.
- Close the door (2.) with the key and place the drip-tray (8.) in front of the machine again.

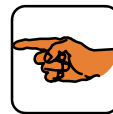

## 6. USE OF THE PROGRAMMING UNIT

The machine is provided with a programme with which you as user can read data and set the machine in accordance with your personal requirements.

### 6.1 Reading out the counter contents or re-setting the counter

- Press the programming button (18.2) to start the programming.

The display alternately shows a three-figure and a six-figure number.

The three-figure number gives the total of the delivered cups, mugs and half or whole jugs **since the last resetting of the counter to zero**. The six-figure number gives the total number of cups, mugs and half or whole jugs that the machine **since coming into operation for the first time** has delivered.

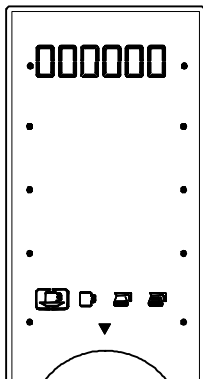

Fig. 6 Counter positions

#### 6.1.1 Reading counter positions of tapped drinks

- Select with the setting key (4.11 or 4.13) cup, mug, half a jug or whole jug.
- Read the counter positions.

#### 6.1.2 Reading counter positions per drink

- Select the desired drink with one of the selection buttons.
- Select with the setting key (4.11 or 4.13) cup, mug, half a jug or whole jug.
- Read the counter positions; a black dot on the display indicates the selected drink.

#### 6.1.3 Resetting the counter positions to zero

- Select any drink with one of the selection buttons.
- Keep the button pressed down during 5 seconds.

The counter for **all** drinks is reset to zero for cups, mugs, half jugs and whole jugs.

#### TIP

- It is not possible to **reset the total counter** of the machine to zero!
- Press the programming button (18.2) to return to the base position of the display.



### 6.2 Setting possibilities

#### TIP

- All changes can be entered consecutively at once, because they succeed each other.
- The following paragraphs describe the procedures per setting possibility, i.e. not consecutively.



#### 6.2.1 Setting the amount of water per drink

At setting the amount of water per drink it should be taken into account that the actual amount of drink **is more** than the amount of water that is set. This is because ingredients are added to the hot water. This particularly happens when tapping a **chocolate drink**.

#### WARNING

- Δ Keep this in mind in order to prevent trouble with cups, mugs and jugs running over.
- Press the programming button (18.2) to start the programming.
- Press one time on the [Enter] key (4.12).



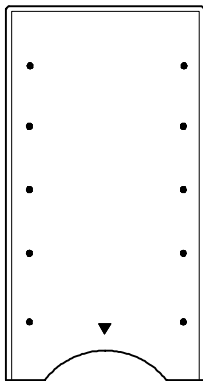

Fig. 7 Initial situation programming

- Press the selection button to be set.

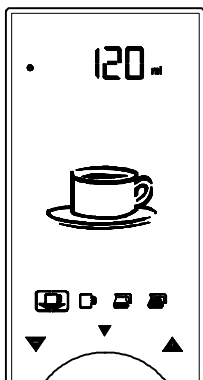

Fig. 8 Setting the amount of drink

- Set with the setting key (4.11 or 4.13) the amount of water.



**TIP**

- By pressing the setting key (4.11 or 4.13) longer you quickly to through the range.
- See table 3 on the supplementary sheet for the factory settings and the (im)possibilities.
- Write your own settings with a pencil in the table.
- Press the [Enter] key (4.12) for setting the values for a **mug**.
- Press the [Enter] key (4.12) for setting the values for **half a jug**.
- Press the [Enter] key (4.12) for setting the values for a **whole jug**.
- Press the programming button (18.2) to finish the programming.

## 6.2.2 Switching on or off the tapping possibilities ‘mug, half a jug or whole jug’

If the machine has been set to paid delivery, tapping a mug, half a jug or a whole jug is **not** possible.

### 6.2.2.1 Switching off

- Decrease the value set for ‘mug’ to the minimum (§6.2.1). The display shows ‘OFF’. Now the tapping possibilities for a mug is switched off. When in use selecting ‘mug’ for the drink involved gives **no** dot on the display; this choice is not possible then.

This tapping possibility can be switched off in the same way for all drinks.

- Press the programming key (18.2) to finish the programming.

### 6.2.2.2 Switching on

- Increase the set value for ‘mug’ (§6.2.1). The display again shows the value that you are to set in ml. Now the tapping possibility for a mug is switched on.

This tapping possibility can be switched on in the same way for all drinks.

- Press the programming key (18.2) to finish the programming.

## 6.2.3 Setting strongness of drink

- Press the programming key (18.2) to start the programming.
- Press one time the [Enter] key (4.12).

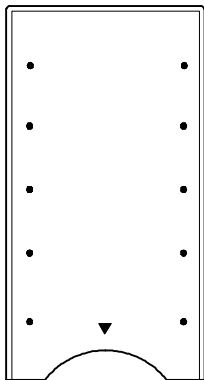

Fig. 9 Initial situation programming

- Select the drink involved.
- Press four times the [Enter] key (4.12).

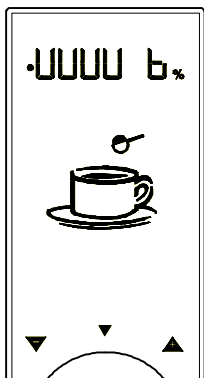

Fig. 10 Strongness drink

The ingredient containers of the machine appear on the screen.



### TIP

- The ingredient container that can be set flashes.
- Set with the setting key (4.11 or 4.13) the strongness.



### TIP

- Write down your own settings with a pencil in the table on the supplementary sheet.
- Press several times the Enter key (4.12) to set the other ingredient containers.

The number of ingredient containers to be set depends on the selected drink, see table 3 on the supplementary sheet.

- Now set with the setting key (4.11 or 4.13) the strongness of the next ingredient container.
- Press the programming key (18.2) to finish the programming.

### TIP

- The machine automatically relates the set percentage to the set amount of water.



## 6.2.4 Setting the hot water temperature

- Press the programming key (18.2) to start the programming.
- Press three times the [Enter] key (4.12).

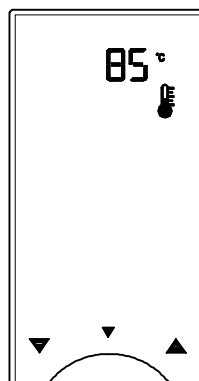

Fig. 11 Temperature setting

- Set with the setting key (4.11 or 4.13) the temperature (from 80°C – 90°C).
- Press the programming key (18.2) to finish the programming.

**The factory setting of the machine is 85°C.**

## 6.2.5 Setting descaling signal

- Press the programming key (18.2) to start the programming.
- Press four times the [Enter] key (4.12).

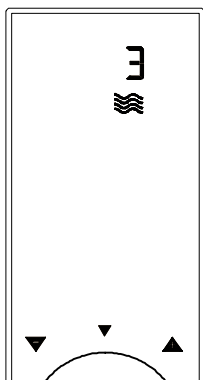

Fig. 12 Descaling signal

- Set with the setting key (4.11 or 4.13) the required value, taking the water hardness into account (table 1).
- Press the programming key (18.2) to finish the programming.

Position	Signal after number of liters	Water hardness		
		°DH	°TH	Description
OFF	No signal	-	-	-
1	± 250 liter	18-30	32-55	hard
2	± 500 liter	12-18	22-32	rather hard
3	± 1000 liter	8-12	15-22	average
4	± 1500 liter	4- 8	7-15	soft
5	± 2000 liter	0- 4	0- 7	very soft
4,0 °DH = 0,714 mmol/liter				
5,6 °DH = 1,000 mmol/liter				
8,0 °DH = 1,429 mmol/liter				
12,0 °DH = 2,143 mmol/liter				
18,0 °DH = 3,214 mmol/liter				
30,0 °DH = 5,357 mmol/liter				
10,0 °TH = 1,000 mmol/liter				

Table 1 Settings water hardness

### TIP

- Inquire with your local waterworks about the hardness of the water supplied and always choose the correct setting. The default setting of the machine is position 3.



The machine automatically records the number of liters of water after each descaling cycle. When the settings are incorrect and/or the descaling sign on the display is ignored, the guarantee is no longer valid!

## 7. MAINTENANCE BY AUTHORIZED USERS

During use calcification takes place in the machine. The machine is provided with a warning system that indicates when the machine must be descaled.

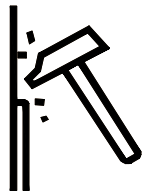

Fig. 13 Descaling signal

When this signal appears on the display the machine **needs** descaling.



### **WARNING**

△ Do **not** ignore this message, otherwise the guarantee will be no longer valid!



### **TIP**

– Regular descaling prolongs the life of your machine!

### 7.1 Descaler



### **WARNING**

△ During descaling wear gloves and facial protection and do not leave the machine during the process.



### **TIP**

– Make sure there is a large receiving bin (min. capacity 7 l) for the liquid that is drained.

- Remove the drip-tray (8.).
- Open the door (2.).
- Lift the cover (1.).
- Remove all ingredient containers (17.) from the machine.
- Press the programming key (18.2).
- Press two times the [Enter] key (4.12).



### **TIP**

– If you do not want to descale, within **10 seconds** press the key (4.13) to stop the descaling programme.

- Press the setting key (4.11).

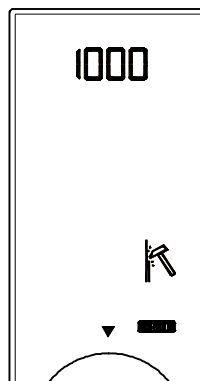

Fig. 14 Descaling programme

The descaling symbol appears on the display. The figure in the upper right corner indicates the number of liters of water that has been used since the last descaling process.

### **WARNING**

△ The water coming out of the drain hose can be very hot.

- Pull the drain hose (21.) about 5 cm out of the machine.
- Place a receiving bin with a capacity of at least 7 litres under the drain hose.



### **TIP**

– Slide the machine to the rim of the blade it stands on, so that a receiving bin can be placed under the drain hose.



- Remove the plug from the drain hose and let the water flow into the receiving bin.
- Place the plug on the drain hose again.
- Place the receiving bin under **both** outlets (5. and 6.).

### **TIP**

– If the descaling has started in the meantime, then push **longer than 10 seconds** on the setting key (4.13) to stop the descaling programme.



**WARNING**

△ The descaling solution will flow out of the hot water outlet as well as out of both drink outlets.

- Solve 100 gr. **Renegite** in 1/2 liter of hot water.
- Remove the plug from the pouring opening (23.).
- Pour the descaling solution in the opening with the help of the delivered funnel.

**WARNING**

△ Stop the descaling programme **never** when you have already poured descaler into the machine!

- Close the pouring opening again with the plug.
- Press the setting key (4.11) to start the descaling.

The machine is now flushed with a mixture of water and descaler. **This takes about 15 minutes.**

At the end of the descaling programme the hammer disappears from the display.

- Remove the plug from the drain hose (21.) and let the water flow into the litter bin.
- Place the plug back on the drain hose.
- Push the drain hose back again.
- Place the ingredient containers (17.) back into their places.
- Close the cover (1.).
- Press the programming key (18.2).
- Close the door (2.).
- Put the drip-tray (8.) back.

Now the machine will be filled with water again and the heating is started.

The descaling signal has been automatically reset to zero.

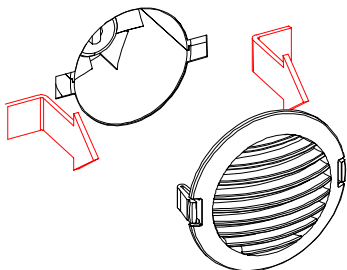

Fig. 15 Removing the fan grille

## 7.2 Cleaning the exhaust fans

The machine is provided with two exhaust fans to exhaust the water vapour above the mixing units. This prevents the inside of the machine and the ingredients in the containers from getting moist.

**CAUTION**

- The exhaust fan works continually when the machine has been switched on with the ON/OFF switch (16.).

**TIP**

- Clean **twice a year** the blades of the exhaust fan to be sure of a good exhaustion.



- Switch the machine **off** with the ON/OFF switch (16.). The switch no longer shows a little red square.
- Remove the fan grille (fig.15 ) by pressing the two lips towards each other and pulling the grille out of the machine.
- Carefully pull the blade wheel from the shaft (fig.16 ).
- Clean the grille and the blade wheel in hot water with a normal washing-up liquid.
- Thoroughly clean the fan housing with a brush.
- Carefully push the blade wheel back onto the fan shaft.
- Replace the grille.
- In the same way clean the grille and the blade wheel at the other side of the machine.

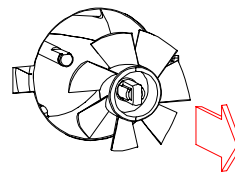

Fig. 16 Removing the fan blade

## 8. CORRECTING MALFUNCTIONS

In case of malfunctions first consult the malfunctions tables. If the problem cannot be solved, consult your Bravilor Bonamat dealer, your service mechanic or one of the service desks.

### 8.1 Malfunctioning analysis general

LIST OF MALFUNCTIONS		
Symptom:	Possible cause:	Actions:
1. The machine does not work and there is nothing on the display.	The plug is not connected to the power socket.	Connect the plug to the power socket.
	External fuse has blown.	Reset or replace the external fuse.
	Group is overloaded.	Connect the machine to another group.
	Switch defect.	Call in service.
2. Sometimes water comes out of the outlet without reason.	Temperature has been set so high that the water starts boiling.	Set the temperature at a lower value, see §6.2.4.
	Leakage at the drive shaft of the mixer in the supporting plate (22.7) because the mixer shaft and the supporting plate are dirty.	Clean the shaft and the supporting plate, see §5.2.3. Call in service.
3. While tapping a drink, also water comes out of the hot water outlet.	Bush siphon housing water selector is dirty.	Descale the machine, see §7.1.
4. Water spontaneously comes out of the drink outlet and from under the machine.	The electrodes are dirty.	Descale the machine, see §7.1.
		Call in service.
5. The machine remains boiling and water keeps running from the outlet.	–	Call in service.
6. No desired quantity of powder and the mixer motor does not run.	The ingredient container concerned is empty.	Fill the corresponding ingredient container.
		Call in service.
7. Lumps in the ingredient outlet.	The fan blade has not been mounted.	Mount the fan blade, see §7.2.
	The fan does not work.	Call in service.
8. The machine restarts the descaling programme at switching on.	The descaling programme has been activated and had not finished yet when the machine was turned off. It will start again at switching on.	Leave the machine on and let the descaling programme run.
		Call in service.
9. Drink comes out of the fan.	The outlet is blocked.	Clean the outlet.

## 8.2 Display messages and their meanings

DISPLAY MESSAGES		
	Possible cause:	Actions:
<b>Error 1</b>	Tap is closed.	Open the tap.
	Water hose is twisted.	Take the twist out of the hose.
	No pressure in the water system.	Check other draw-off points in the building for pressure and investigate the cause.
<b>Error 2</b>	Leak in the water system.	Close the water supply valve and take the plug out of the socket. Call in service.
<b>Error 3</b>	Temperature sensor in the machine is defect.	Call in service.
<b>Error 4</b>	Temperature sensor or boiling safety device has activated itself.	Call in service.
<b>Error 5</b>	N/A to this application.	N/A to this application.
<b>Error 6</b>	Photoelectric cell defect.	Call in service.
	Wear or breach of a selector component.	Call in service.
	Water selector motor defect.	

## 9. CONSUMABLE ITEMS AND ACCESSORIES

### 9.1 Recommended consumable items

Description	Ordering number	Quantity
Descaler (RENEGITE)	7.190.101.103	48 x 50 gr.
	7.190.103.103	40 x 100 gr.
	7.190.102.101	6 x 1 kg.

### 9.2 Accessories

#### 9.2.1 Raising feet

Set of extra feet to raise the apparatus **2 cm** so that larger cups or cans can be placed under the drink outflow. Now the drip tray is standing loose in front of the machine.

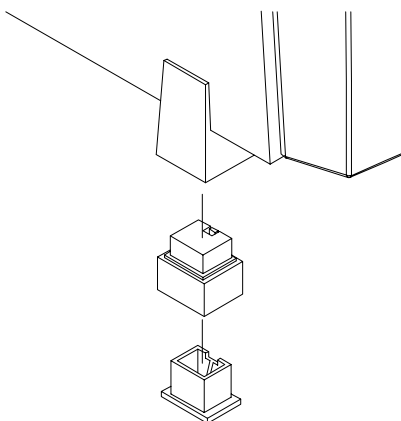

*Fig. 17 Raising foot*

Ordering number: 7.270.201.101 (set of 4 pieces)